

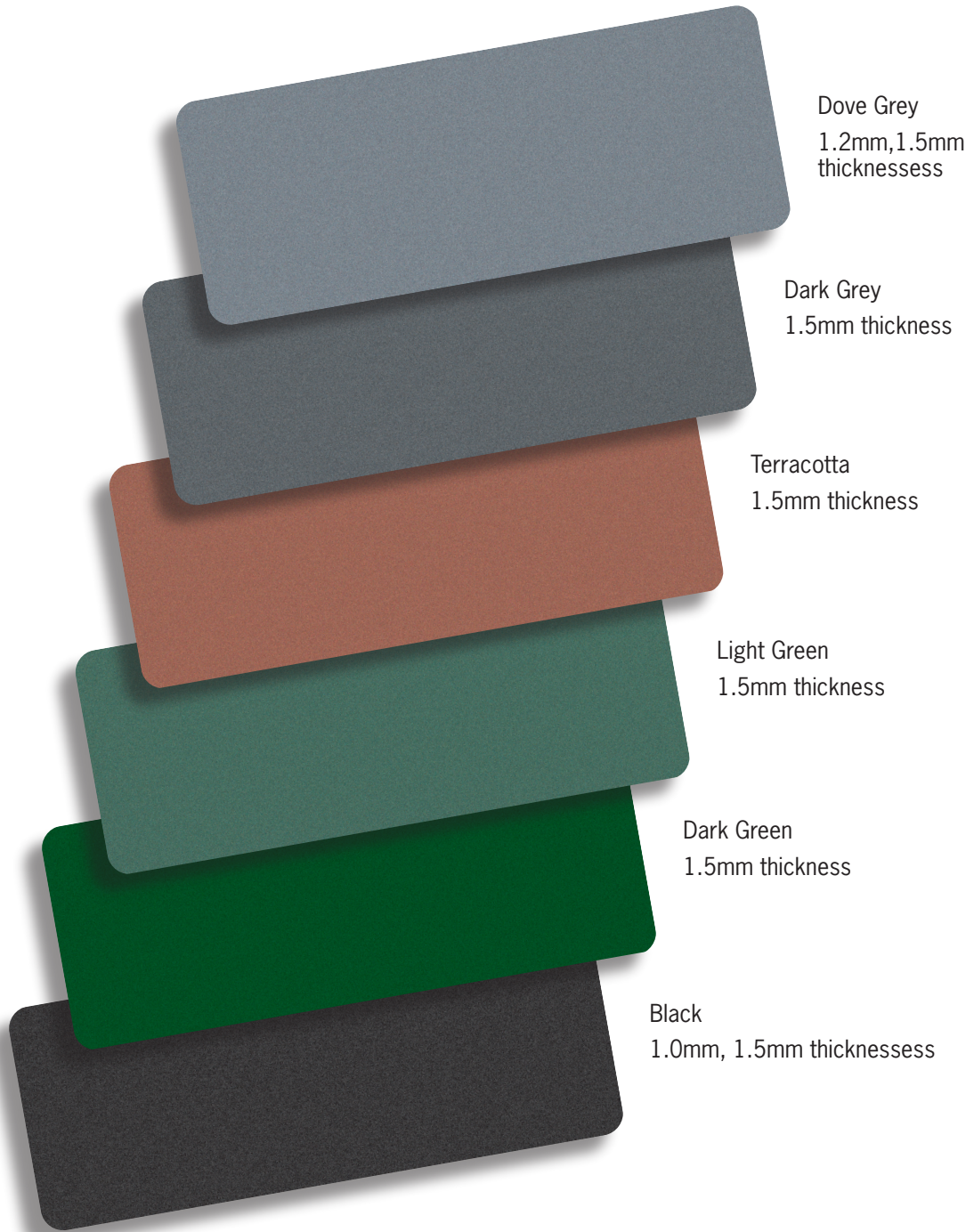

Butynol® Membranes

2	Butynol® Colour Range
3-25	Butynol® Roofing
4-8	Butynol® and Eco Butynol® BRANZ Appraisal
27-29	Eco Butynol®
31-34	Undertile BRANZ Appraisal
35-38	Undertile Butynol®
39-40	Butynol® Shingles
41-43	Optima
45-46	Bonding/Seam Primer
47-49	Butynol® Sealant

ARDEX Butynol® Colour Range



Colours shown may vary from actual material samples.
Please check actual colour of material before ordering.



ARDEX Butynol®

**BRANZ Appraised,
E2/AS1 Acceptable Solution**

DISCLAIMER The technical details, recommendations and other information contained in this data sheet are given in good faith and represent the best of our knowledge and experience at the time of printing. It is your responsibility to ensure that our products are used and handled correctly and in accordance with any applicable New Zealand Standard, our instructions and recommendations and only for the uses they are intended. We also reserve the right to update information without prior notice to you to reflect our ongoing research and development program. Country specific recommendations, depending on local standards, codes of practice, building regulations or industry guidelines, may effect specific installation recommendations. The supply of our products and services is also subject to certain terms, warranties and exclusions, which may have already been disclosed to you in prior dealings or are otherwise available to you on request. You should make yourself familiar with them.



BRANZ Appraised

Appraisal No.436 [2011]

BRANZ Appraisals

**Technical Assessments of products
for building and construction**

**BRANZ
APPRAISAL
No. 436 (2011)**

This Appraisal replaces BRANZ
Appraisal No. 436 (2005) dated
11 July 2005.

Amended 15 July 2011.

**BUTYNOL® AND ECO
BUTYNOL® ROOFING
MEMBRANES**

Ardex New Zealand Limited
P O Box 19549
Woolston
Christchurch

Tel: 03 384 3029
Fax: 03 384 9779
www.butynol.co.nz



BRANZ
BRANZ Limited
Private Bag 50 908
Porirua City
New Zealand
Tel: +64 4 237 1170
Fax: +64 4 237 1171
www.branz.co.nz



Product

1.1 Butynol® and ECO Butynol® Roofing Membranes are synthetic rubber waterproofing membranes designed to be used on roofs and decks.

1.2 The products are supplied as single-ply, flexible synthetic rubber sheet in roll form, with the ECO Butynol® having polypropylene filaments welded to the underside for better wetting by water based adhesives. The products are installed as single layer systems.

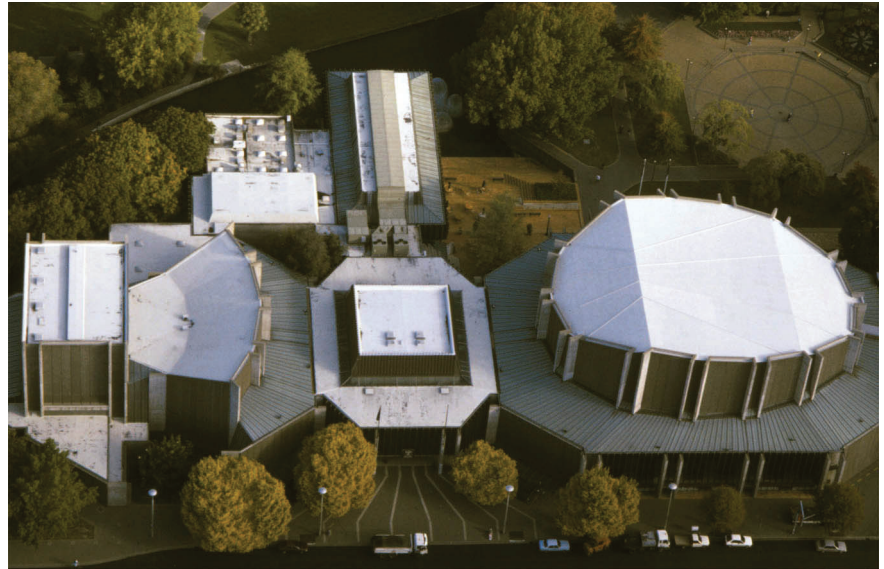

1mm Butynol laid in 1972. The main auditorium roof is still in service after 39 years. Some of the other low slope roofs are due to be upgraded with new Butynol during current building refurbishment.

Scope

2.1 Butynol® and ECO Butynol® Roofing Membranes have been appraised for use as waterproofing membranes for buildings within the following scope:

- scope limitations of NZBC Acceptable Solution E2/AS1, Paragraph 1.1; and,
- with timber supporting structures designed and constructed in accordance with the NZBC; and,
- with nominally flat or pitched roofs constructed to drain water to gutters and drain outlets complying with NZBC; and,
- with substrates of plywood sheet; and,
- with decks that have a maximum size of 40m².

2.2 Butynol® and ECO Butynol® Roofing Membranes have also been appraised for use as waterproofing membranes for external reinforced concrete and plywood roofs, pedestrian decks and balconies for buildings within the following scope:

- up to 3 storeys with a maximum height from ground to eaves of 10m and with a floor plan area limited only by seismic and structural control joints; and,
- with the reinforced concrete structure designed and constructed in accordance with the NZBC; and,
- with timber supporting structures designed and constructed in accordance with the NZBC; and,
- subjected to maximum wind pressures (refer Paragraph 8.1); and,
- with nominally flat, curved or pitched roofs constructed to drain water to gutters and drain outlets complying with NZBC.

2.3 This Appraisal is limited to roofs, decks and balconies within the following scope:

- constructed to suitable falls (Refer Paragraph 13.1 – 13.9); and,
- with no steps within the deck level, no integral roof gardens and no down pipe discharging directly onto the deck.

2.4 The design and construction of the substrate and movement and control joints is specific to each building, and therefore the responsibility of the building designer and building contractor and is outside the scope of this Appraisal.

2.5 The membranes must be installed by Ardex New Zealand Limited approved applicators.

Building Regulations

New Zealand Building Code (NZBC)

3.1 In the opinion of BRANZ, Butynol® and ECO Butynol® Roofing Membranes, if designed, used, installed and maintained in accordance with the statements and conditions of this Appraisal, will meet the following provisions of the NZBC:

Clause B2 DURABILITY: Performance B2.3.1 (b) 15 years. Butynol® and ECO Butynol® Roofing Membranes meet this requirement. See Paragraph 10.1.

Clause E2 EXTERNAL MOISTURE: Performance E2.3.1 and E2.3.2. Roofs, Decks and balconies incorporating Butynol® and ECO Butynol® Roofing Membranes meets these requirements. See Paragraphs 13.1 – 13.3.

Clause F2 HAZARDOUS BUILDING MATERIALS: Performance F2.3.1. Butynol® and ECO Butynol® Roofing Membranes meet this requirement and will not present a health hazard to people.

3.2 This Appraisal appraises an **Acceptable Solution** in terms of New Zealand Building Code compliance and the product complies with NZBC Acceptable Solution E2/AS1 Paragraph 8.5. This product is also appraised as an Alternative Solution as outlined in Paragraph 2.2.

Technical Specification

4.1 Materials supplied by Ardex New Zealand Limited are as follows:

Butynol® Membranes

- All membranes are single-ply, flexible synthetic rubber membranes. They are supplied in rolls nominally 1.4 metres wide by 17.86 metres long. Each roll is packed in polythene wrapper trademarked 'Butynol®' with thickness identified. Gauges available are 1.0, 1.5 and 2.25mm in black and 1.5mm in six colours.

ECO Butynol® Membrane

- All membranes are single-ply, flexible synthetic rubber membranes with polypropylene filaments welded to the underside. They are supplied in rolls nominally 1.4 metres wide by 17.86 metres long. Gauges available are 1.0, 1.5 and 2.25mm in black, 1.2 mm in Dove Grey and 1.5mm in six colours.

Adhesive WPM 09A

- A contact brushing, spray grade and rolling solvent free adhesive for fixing to the ECO Butynol to substrates. Supplied in 20L plastic containers.

Adhesive WPM 09C Catalyst

- Used with the WPM 09A to assist adhesion in adverse conditions. Supplied in 1, 4 and 20 litre containers.

Adhesive WA98

- A specially formulated solvent-based adhesive for all Butynol® applications. Supplied in 1, 4 and 20 litre containers.

Seam Primer

- A water resistant primer adhesive, used with seam tape for general lap bonding.

Seam Tape

- Uncured cold gum tape used for general lap bonding and laps likely to be subject to periodic ponding. Supplied in 50mm x 30.5 metre rolls.

Flashing Tape

- A malleable tape for moulding gussets, pipe flashings and awkward situations. Supplied in widths of 50-100mm x 5 metres long.

Butynol Sealant

- A specially designed and formulated sealant for sealing Butynol® flashings into chases. Supplied in 375mm tubes.

Handling and Storage

5.1 Handling and storage of all materials whether on or off site is under the control of the Ardex New Zealand Limited approved applicators. Dry storage must be provided for all products and the rolls of membrane must be stored in an upright position.

Technical Literature

6.1 Refer to the Appraisals listing on the BRANZ website for details of the current Technical Literature for the Butynol® and ECO Butynol® Roofing Membranes. The Technical Literature must be read in conjunction with this Appraisal. All aspects of design, use, installation and maintenance contained in the Technical Literature and within the scope of this Appraisal must be followed.

Design Information

General

7.1 Butynol® and ECO Butynol® Roofing Membranes are for use on roofs, decks and balconies where an impervious waterproof membrane is required to prevent damage to building elements and adjoining areas.

7.2 The 1.0mm thickness product is designed for use on roofs and gutters, and will accommodate light traffic; the 1.5mm is for walk out decks and high maintenance areas; and the 2.25mm is a heavy duty product that is custom made on request. The 1.2mm is available in ECO Butynol® only is for use on roofs.

7.3 The effective control of internal moisture must be considered at the design stage due to the impermeability of the membrane. Refer to BRANZ publication "Good Practice Guide to Membrane Roofing".

7.4 Timber framing systems must comply with NZS 3604, or where specific engineering design is used, the framing shall be of at least equivalent stiffness to the framing provisions of NZS 3604, or comply with the serviceability criteria of NZS 4203. In all cases framing must be provided so that the maximum span of the substrate as specified by the substrate manufacturer is met and that all sheet edges are fully supported.

Building to NZBC Acceptable Solution E2/AS1

7.5 NZBC Acceptable Solution E2/AS1 limits the size of decks to 40 m² as covered by the scope of this Appraisal. Butynol® and ECO Butynol® Roofing Membranes are suitable for use on decks larger than 40 m². These decks are the subject of specific design and are outside the scope of this Appraisal.

Structures

8.1 Butynol® and ECO Butynol® Roofing Membranes fully bonded are suitable for use in areas subject to maximum wind pressure of 3 kPa Ultimate Limit State subject to the limitations of the substrates.

Substrates

Plywood

9.1 Plywood must be treated to H3 (CCA treated). LOSP treated plywood must not be used. Plywood must comply with NZBC Acceptable Solution E2/AS1 Paragraph 8.5.3 and 8.5.5. Where specific design is used (i.e. outside the scope of E2/AS1), the plywood thickness and fixing size may increase and centres may decrease to meet specific wind loadings.

Concrete

9.2 Concrete substrates must be to a specific engineering design meeting the requirements of the NZBC, such as concrete construction to NZS 3101.

Durability

Serviceable Life

10.1 Butynol® and ECO Butynol® Roofing Membranes when subjected to normal conditions of environment and with proper maintenance can expect to have a serviceable life of at least 20 years.

Maintenance

11.1 No maintenance of the membrane is normally required provided significant substrate movement does not occur.

11.2 In the event of damage to the membrane, the membrane must be repaired by removing the damaged portion and applying a patch as for new work.

11.3 Drainage outlets must be maintained to operate effectively.

Outbreak of Fire

12.1 The membranes must be protected from heat sources such as flues and chimneys in accordance with the requirements of NZBC Acceptable Solution C/AS1 Part 9 for the protection of combustible materials.

External Moisture

13.1 Roofs, decks and balconies must be designed and constructed to shed precipitated moisture. They must also take account of snowfalls in snow prone areas. A means of meeting code compliance with NZBC Clause E2.3.1 is given by the Technical Literature which matches details in NZBC Acceptable Solution E2/AS1.

13.2 When installed in accordance with this Appraisal and the Technical Literature, Butynol® and ECO Butynol® Roofing Membranes will prevent the penetration of water and will therefore meet code compliance with Clause E2.3.2. The membranes are impervious to water and will give a weathertight roof, roof deck or balcony.

13.3 The minimum fall to roofs is 1 in 40, decks and balconies 1 in 60 and gutters 1 in 100 with no seams in the gutter closer than 1 m to an outlet in accordance with NZBC Acceptable Solution E2/AS1 Paragraph 8.5.1. All falls must slope to an outlet. Inadequate falls will allow moisture to collect and may increase the risk of deterioration of the membranes. *(Note: Where possible a minimum fall of 1 in 60 in gutters is preferred.)*

13.4 Roof, deck and balcony falls must be built into the substrate and not created with mortar screeds applied over the membranes.

13.5 Allowance for deflection and settlement of the substrate must be made in the design of the deck or balcony to ensure falls are maintained and no ponding of water can occur.

13.6 Drainage flanges must be used for any outlet and must be fitted with a grate or cage to reduce potential sources of blockages. An overflow must be provided where the deck or balcony does not drain to an external gutter or spouting.

13.7 Penetrations and upstands of the membrane must be raised above the level of any possible flooding caused by blockage of deck and balcony drainage.

13.8 The design of details not covered by the Technical Literature is subject to specific weathertightness design and is outside the scope of this Appraisal.

13.9 Butynol® and ECO Butynol® Roofing Membranes are impermeable; therefore a means of dissipating construction moisture must be provided in the building design and construction to meet code compliance with Clause E2.3.6.

Water Supplies

14.1 Water is not contaminated by Butynol® and ECO Butynol® Roofing Membranes. The first 25 mm of rainfall from a newly installed Butynol® and ECO Butynol® Roofing Membranes roof must be discarded before drinking water collection starts. This is to remove residues which may have developed in the processes involved in the production of a Butynol® and ECO Butynol® Roofing Membranes.

14.2 Note that all water collected off roof surfaces made from any material is considered to be non-potable due to possible contamination from other sources. Water collection in this way can only be considered potable if it has been passed through a suitable sterilization system. Sterilization systems have not been assessed and are outside the scope of this Appraisal.

Installation Information

Installation Skill Level Requirement

15.1 Installation of the membranes must be completed by approved applicators, approved by Ardex New Zealand Limited.

15.2 Installation of substrates must be completed by tradespersons with an understanding of roof, deck and balcony construction, in accordance with instructions given within the Ardex New Zealand Limited Technical Literature and this Appraisal.

Preparation of Substrates

16.1 Substrates must be dry, clean and stable before installation commences. Surfaces must be smooth and free from nibs, sharp edges, dust, dirt or other materials such as oil, grease or concrete formwork release agents. All surface defects must be filled to achieve an even and uniform surface.

16.2 Concrete substrates can be checked for dryness by using a hygrometer, as set out in BRANZ Bulletin No. 424. The relative humidity of the concrete must be 75% or less before membrane application.

16.3 The moisture content of a timber substructure must be a maximum of 20% and plywood sheet must be dry at time of membrane application. This will generally require plywood sheets to be covered until just before the membrane is laid, to prevent rain wetting.

16.4 In cases of extreme absorbency a priming coat of 50/50 solution of WA98 and adhesive solvent may be required, consult with the Ardex New Zealand Limited if in doubt.

Membrane Installation

17.1 The membranes must be installed in accordance with the Technical Literature.

17.2 Plywood joints must be taped with 25mm wide PVC pressure sensitive tape.

17.3 The membranes must be unrolled without tension onto the prepared substrate and allowed to 'relax' for at least 20 minutes prior to installation.

17.4 Adhesive must be applied to both the membrane and the substrate, one half at a time. When the adhesive is tack dry, the sheet is rolled onto the substrate. The process is then repeated for the other half of the sheet. Joints in substrates with a pitch of 5° or less, all coloured membranes and ECO Butynol® irrespective of pitch, all guttering and areas subjected to periodic ponding require lap bonding using Ardex seam tape. Joints in substrates with a pitch above 5° can be sealed using WA98 adhesive; this applies to the black Butynol® only.

Inspections

18.1 Critical areas of inspection for waterproofing systems are:

- Construction of substrates, including crack control and installation of bond breakers and movement control joints.
- Moisture content of the substrate prior to the application of the membrane.
- Acceptance of the substrate by the membrane installer prior to application of the membrane.
- Installation of the membrane to the manufacturer's instructions.

Health and Safety

19.1 Safe use and handling procedures for the membrane system is provided in the Technical Literature.

The products must be used in conjunction with the relevant Materials Safety Data Sheet for each membrane.

Basis of Appraisal

The following is a summary of the technical investigations carried out:

Tests

20.1 Tests have been carried out on the membranes by Materials and Quality Consultancy Ltd. This testing covered specific gravity, shore hardness, tensile strength, modulus of elongation, elongation at break, tensile and elongation retention after heat aging, tear strength, ozone resistance and water absorption as detailed in NZBC Acceptable Solution E2/AS1 Paragraph 8.5.4(b). Results and test methods have been reviewed by BRANZ and found to be satisfactory.

20.2 Water vapour permeability tests have been undertaken by BRANZ in accordance with ASTM E96.

20.3 The adhesives, primers and seam tapes used with Butynol® and ECO Butynol® Roofing Membranes meet the performance requirements of NZBC Acceptable Solution E2/AS1 Paragraph 8.5.4(c).

Results and test methods have been reviewed by BRANZ and found to be satisfactory.

Other Investigations

21.1 An assessment was made of the durability of the Butynol® Roofing Membrane by BRANZ technical experts using NZBC B2/VM1 History of Use.

21.2 Site visits have been carried out by BRANZ to assess the practicability of installation, and to examine completed installations.

21.3 The Technical Literature has been examined by BRANZ and found to be satisfactory.

Quality

22.1 The manufacture of the Butynol® and ECO Butynol® Roofing Membranes has been examined by BRANZ, and details regarding the quality and composition of the materials used were obtained by BRANZ and found to be satisfactory. The membranes manufacturer is the subject of AS/NZS ISO 9001: 2008 Certificate by Telarc Limited.

22.2 The quality of manufacture of the products is the responsibility of Ardex New Zealand Limited.

22.3 The quality of supply of the products to the market is the responsibility of Ardex New Zealand Limited.

22.4 Quality on site is the responsibility of the Ardex New Zealand Limited approved applicators.

22.5 Designers are responsible for the substrate design, and building contractors are responsible for the quality of construction of substrate systems in accordance with the instructions of the substrate manufacturer, Ardex New Zealand Limited and this Appraisal.

Sources of Information

- AS/NZS 2269: 2008 Plywood – Structural.
- ASTM E 96-02 Water vapour transmission of materials in sheet form, American Society of Testing Materials, Philadelphia, 1992.
- NZS 3101: 1995 The design of concrete structures.
- NZS 3604: 1999 Timber framed buildings.
- NZS 3604: 2011 Timber-framed buildings.
- Compliance Document for New Zealand Building Code External Moisture Clause E2, Department of Building and Housing, Third Edition July 2005.
- New Zealand Building Code Handbook and Approved Documents, Building Industry Authority, 1992.
- The Building Regulations 1992, up to, and including October 2004 Amendment.
- Membrane Roofing Good Practice Guide, BRANZ, November 1999.



The new Christchurch Airport Terminal has been covered with 1.5mm Dove Grey Butynol.



BRANZ

In the opinion of BRANZ, **Butynol®** and **ECO Butynol® Roofing Membranes** are fit for purpose and will comply with the Building Code to the extent specified in this Appraisal provided they are used, designed, installed and maintained as set out in this Appraisal.

The Appraisal is issued only to **Ardex New Zealand Limited**, and is valid until further notice, subject to the Conditions of Appraisal.

Conditions of Appraisal

1. This Appraisal:
 - a) relates only to the product as described herein;
 - b) must be read, considered and used in full together with the technical literature;
 - c) does not address any Legislation, Regulations, Codes or Standards, not specifically named herein;
 - d) is copyright of BRANZ.
2. **Ardex New Zealand Limited:**
 - a) continues to have the product reviewed by BRANZ;
 - b) shall notify BRANZ of any changes in product specification or quality assurance measures prior to the product being marketed;
 - c) abides by the BRANZ Appraisals Services Terms and Conditions.
 - d) Warrants that the product and the manufacturing process for the product are maintained at or above the standards, levels and quality assessed and found satisfactory by BRANZ pursuant to BRANZ's Appraisal of the product.
3. BRANZ makes no representation or warranty as to:
 - a) the nature of individual examples of, batches of, or individual installations of the product, including methods and workmanship;
 - b) the presence or absence of any patent or similar rights subsisting in the product or any other product;
 - c) any guarantee or warranty offered by **Ardex New Zealand Limited**.
4. Any reference in this Appraisal to any other publication shall be read as a reference to the version of the publication specified in this Appraisal.
5. BRANZ provides no certification, guarantee, indemnity or warranty, to **Ardex New Zealand Limited** or any third party.

For BRANZ

P Burghout
Chief Executive

Amendment No. 1, dated 15 July 2011.

This Appraisal has been amended to align the minimum fall requirements as specified in Acceptable Solution E2/AS1.

Date of issue: 23 May 2011

ARDEX Butynol®

BRANZ Appraised, E2/AS1 Acceptable Solution



BUTYNOL® SYSTEM SPECIFICATION

A synthetic rubber with properties which resist ageing from heat, sunlight and ozone. It has excellent gas impermeability and toughness and remains flexible at low temperatures.

Butynol® is manufactured by combining the petroleum gases isobutylene and isoprene at the extremely low temperature of -100°C . (Rubber Technology–Morton)

Butynol® is marketed by Ardex as a warranted roofing, decking and tanking product and fixed by their trained and experienced approved Applicators.

BUTYNOL® MATERIAL SPECIFICATIONS

Our requirements for long term warranty necessitate that Butynol® meets these typical technical requirements:

Specific Gravity to ASTM D297	1.20±0.05
Hardness IRHD to ASTM D1415	65±5
Tensile Strength to ASTM D412	8.3 MPa min
Modulus at 300% elongation to ASTM D412	4.15 MPa min
Elongation at break to ASTM D412	300% min
Heat Ageing (7 days at 115°C)	
Tensile Retention to ASTM D412	70% min
Elongation Retention to ASTM D412	70% min
Tear Strength to ASTM D624	26kN/m
Ozone Resistance to ASTM D1149 (7 days at 40°C in 50pphm ozone)	No visible cracks
Water Absorption to ASTM D471	
1.65% (by mass) 0.72% (by volume)	
Water Permeability to ASTM E96-92	
Vapour Flow Resistance (MNs/g)	12414
Vapour Flow Rate ($\text{g}/\text{m}^2\text{d}$)	0.013

Note: Interesting comparable figures for water permeability are –
Polythene 156, Asphalt 1830, P.V.C. 4900.

K Values on 1mm Butynol sheeting

K Value (Thermal Conductivity) 7.4×10^3
Cal/cm/sec/deg C.

Conductivity Data on 1mm Butynol sheeting

Resistance/ m^2 $\Omega/\text{m}^2 = 0.6816$ on 9.3 volts.

SEAM TAPE PERFORMANCE

Tests on the seam tape bonding method, by an

independent testing laboratory, have shown average values equivalent to 90% of unwelded material. It is considered impossible for the test methods used to be duplicated in normal service ie. 400% elongation.

BUTYNOL® PROTECTION

Butynol® protects against water, moisture vapour, gases, sun, ozone, frost, acids, chemicals and bacteria.

BUTYNOL® RESISTANCE

Butynol® resists tearing, flex cracking, bubbling and abrasion. It is extremely strong, has a long life and is versatile.

STAINING OF LIGHT COLOURED BUTYNOL®

To avoid staining care must be taken during design stage to ensure that water running off unpainted treated timber and some metals (eg copper) do not run over light coloured Butynol®.

BUTYNOL® GAUGES

Standard 1.0mm and 1.2mm–For roofs, gutters and decks with protection.

1.2mm–For roofs.

1.5mm–For roofs, gutters and walk out decks.

2.25mm Heavy Duty

Factory welded panels in all gauges can be custom made.

BUTYNOL® IS PACKAGED

In rolls of nominal 1.4m width and 17.86m long. Each roll is packed in polythene wrapper trademarked Butynol® with thickness identified. Coverage 25m^2 except 2.25mm gauge which is 12m^2

Gauges available are:

1.0mm black. Weight: nominal 30kg

1.5mm black. Weight: nominal 45kg

2.25mm black. Weight: nominal 32kg

1.2mm dove grey. Weight: nominal 32kg

1.5mm all colours. Weight: nominal 47kg

ADHESIVES AND SOLVENTS

Specially formulated for all Butynol® applications. Available in solvent and water based. Supplied in 20L steel/plastic pails (approx. 20kg). 4 and 1 litre cans.

BUTYNOL® SEALANT

Available in tubes for caulking guns.

ARDEX Butynol®

BRANZ Appraised, E2/AS1 Acceptable Solution

SEAM PRIMER

Seam Primer is specially formulated for use with Seam Tape. Applied with scrubber pads. Available in 4 and 1 litre cans.

SEAM TAPE

Recommended for all Butynol® laps.

Supplied by Ardex in 50mm x 30.5m rolls (6 to a carton).

DETAIL TAPE (uncured)

A malleable exterior tape for flashing exterior corners etc. 150mm x 30.5m rolls.

FLASHING TAPE

A malleable tape for moulding in gussets, pipe flashings and awkward situations. Supplied in 100mm x 5m rolls. Flashing tape must not be left exposed. A cover strip of Butynol® or detail tape must be applied over flashing tape to finish.

PLYWOOD TREATMENT

To be in accordance with Acceptable Solution E2/AS1 plywood substrate must be treated to H3.2 with Waterborne CCA treatment and kiln dried after treatment. All plywood joints should be taped with Ardex Release tape.

Plywood must not be LOSP treated.

DURABILITY

Butynol® when fixed according to Ardex instruction will meet the NZBC requirements of B2.3.1(b) 15 years. Refer BRANZ Appraisal Certificate No 436 (2011).

EXTERNAL MOISTURE

New Zealand Building Code Acceptable Solution E2/AS1 requirements recommend membrane clad roofs have a minimum pitch of 2° (1:30).

BUILDING TO NZBC ACCEPTABLE SOLUTION E2/AS1

NZBC Acceptable Solution E2/AS1 limits the size of decks to 40m² as covered by the scope of Appraisal No. 436 (2011). Butynol® Roofing Membrane is suitable for use on decks larger than 40m². These decks are the subject of specific design and are outside the scope of E2/AS1.

CLEANING WEATHERED BUTYNOL®

Use sugar soap to remove oxidation and restore surface. Wind blown dirt is more noticeable on low slope roofs, particularly on black Butynol®.

DAMP AND WEATHERPROOFING

The Building Code of Australia Deemed-to-Satisfy Provisions F1.9 and F1.10 are met by Butynol as an acceptable damp-proof course.

Butynol® when used as described in ABSAC Technical Opinion 188 August 1994 complies with the Building Code of Australia Deemed-to-Satisfy Provision F1.7(b) and Acceptable Construction Manual Part 3.8.1.0, or AS 3740 for "Water Proofing of Wet Areas in Buildings".

PAINTING OVER BUTYNOL®

Use Ardex WPM 908. Wash with Sugar Soap. Beware of using non Ardex primers as this may effect your Butynol® Warranty.

FIRE RATING

The Butynol® roofing system must be considered combustible but may be used on buildings for all purpose groups, subject to the requirements of NZBC Acceptable Solution C/AS1 Part 7, Paragraph 7.11.1.

When used for roofs in Purpose Groups SC and SD a non-combustible substrate or timber 18mm thick is acceptable. Refer 7.11.1.

Building Code of Australia allows use in all building types under Specification C1.10, Clause 7(e), except in bush fire prone areas.

PRODUCT WARRANTY

When laid by an approved Applicator in accordance with Ardex's specifications, a material warranty for up to 20 years (covering the Membrane, adhesive and tape) is available.

WORKMANSHIP

A warranty for workmanship shall be provided directly by the approved Applicator. The period and terms of the workmanship warranty shall be determined by the conditions of contract or the approved Applicator.

ADHESIVES AND SOLVENTS FOR USE WITH BUTYNOL®

- WA98 - The Standard contact brushing, spray grade and rolling adhesive for fixing to the substrate and for laps not subject to periodic ponding.
(Pitch 5° and above)
- WA98S - Solvent for clean up of WA98 adhesive.
- WPM 09A - Solvent free spray/brush adhesive.
(for use with Eco Butynol®)
- WPM 09C - Solvent free catalyst used in conjunction with WPM 09A
(for use with Eco Butynol®)
- Seam Primer - A water resistant primer, used with seam tape for general lap bonding.

Note: Temperature and Humidity

The evaporation of any solvent adhesive system causes a drop in temperature at the interface. At times of high humidity this can result in a micro molecular water layer at the interface which will result in a failure to bond, falsely attributed to Adhesive failure. Fixing should not proceed under these circumstances.

NOTES

1. In cases of extreme absorbency, a priming coat of 50/50 WA98 adhesive and solvent may assist water shedding and absorption. However, a follow up of full strength adhesive for full bonding should not be proceeded with under four hours, thus allowing full evaporation of solvents absorbed into the substrate. Primers must be time dried not touch dried.
2. As new substrate materials continually appear on the market, consult Ardex for approval of their use with Butynol®.
3. Seam tape and seam primer must be used for all Butynol® joints.
4. Do not use in temperatures less than 6°C.

ARDEX Butynol®

BRANZ Appraised, E2/AS1 Acceptable Solution

SUBSTRATE SPECIFICATION (Plywood)

To conform with Acceptable Solution E2/AS1 plywood shall be:

A minimum of 17mm complying with AS/NZS 2269, at least CD Structural Grade plywood with the sanded C face upwards, and H3.2 with Waterborne CCA treatment and kiln dried after treatment.

Substrates must be dry when Butynol® is applied. The plywood and the timber substructure shall have a maximum moisture content of 20% when Butynol is adhered.

Plywood panels shall be laid with staggered joints (brick bond), the edge of sheets shall be supported with dwangs or framing, unless a structurally tested tongue-in-groove edge provides equivalent support. The maximum recommended span in E2/AS1 is 400mm. However specific design may allow 17.5mm plywood or greater to be laid on 400mm purlins with nogs or dwangs at 600mm or even 1200mm centres. Plywood shall be laid with the face grain at right angles to the supports. A 20mm triangular fillet shall be used at the base of any 90° upstand. External edges shall be chamfered with a minimum radius of 5mm.

Plywood shall be fixed with 10 gauge x 50mm stainless steel countersunk head screws with 3mm gaps between all sheets, at 150mm centres on edges, and 200mm in the body of the sheets.

All joints in the plywood and junctions of plywood with other materials shall have 25mm Ardex Release tape applied before application of Butynol®.

PLYWOOD QUALITY

Plywood to be installed in accordance with the plywood manufacturer's recommendation to provide a suitable surface for membrane.

Problems with plywood quality may effect long term membrane performance.

Please check with your plywood supplier.

We have duplicated the position of one supplier below.

- Face checks in plywood do not affect the structural integrity of the panel as they are confined to the surface veneer and are strictly aesthetic in nature.
- As face checking occurs naturally Carter Holt Harvey Woodproducts does not consider them to be a manufacturing or product fault.

Source: *Specifications and Installation Guide Carter Holt Harvey.*

Laying on plywood with face checking as above should be avoided and surface corrected if possible.

NOTE: The use of LOSP (Light Organic Solvent Preservative) treated plywood must NOT be used under Butynol® in any circumstances or conditions.

SUBSTRATE SPECIFICATION (Concrete)

New concrete

Must be cured for a minimum of 28 days and all curing compounds removed prior to application.

A reduction in cure time can be achieved by utilising the Ardex HydrEpoxy System (consult Ardex Technical Department for details).

Old concrete

Must be clean from any contaminants prior to application.

For further substrate types please consult Ardex Technical Department.

ROOF VENTILATION

The most important precaution to observe with low slope roofs is that no construction moisture is enclosed. Low slope or flat roof structures are generally slow drying because of their impermeable cladding. All timbers should be below 20% moisture before being enclosed.

No amount of ventilation will cope with moisture problems created by drying timbers.

If there is a reason to believe that there is moisture trapped in the roof structure Ardex can provide our standard one way substrate ventilators or our lo rise one way ventilators to provide a better visual appearance.

Soffit ventilation is the most effective way to provide effective roof cavity ventilation. Careful placement of the soffit ventilation to avoid gutters etc, will provide a natural airflow as well as cooling to a low slope membrane clad roof.

Closed-in construction spaces under Butynol® roofs and decks shall have adequate ventilation to prevent the accumulation of moisture under Butynol®. There should be a minimum gap of 20mm between the underside of the substrate and any insulation.

SUBSTRATE VENTILATION

Substrate ventilation should be used to release moisture trapped under the Butynol® on concrete surfaces. Substrate ventilators are used in conjunction with vent tapes. Tapes should be laid in a grid pattern spaced at 600mm venting to the roof perimeter. On plywood substrates ventilators are used at the junction of the ply. Ventilators are not required in most applications for cavity ventilation - seek advice from an Ardex Representative. One way substrate ventilators prevent moisture vapour build up and if required can be installed every 90 square metres. Not designed to ventilate roof cavities. (Refer Diagram page 20).

TYPICAL ARCHITECTURAL BUTYNOL® RUBBER ROOFING SPECIFICATION

1. Preliminary

Refer to the Preliminary and General Clauses of this specification and to the General Conditions of Contract which are equally binding on all trades. This section of the specification shall be read in conjunction with all other sections.

2. Scope

This section of the contract consists in general of the provision and laying of all the Butynol® rubber, for the roofs, decks, gutters and flashings on the buildings. Refer to Clause 12 hereafter for Extent of Work.

3. Workmanship

The whole of the work shall be carried out by skilled tradesmen using adequate and proper equipment and methods in accordance with best trade practice, and following the specifications methods and recommendations as laid down by the manufacturers.

4. Sub-contractors

The work included in this section of the contract shall be carried out by a firm of roofing experts conversant with and specialising in the supply and fixing of this material and shall be a firm approved by Ardex.

5. Warranty

When laid by an approved Applicator in accordance with Ardex's specifications, a written material warranty of up to 20 years is available. It is the responsibility of the approved Applicator to confirm proper installation and to request Ardex to issue a material warranty on behalf of the customer following completion of installation.

6. Materials

6.1 Butynol® Rubber

(a) Shall be 1.0mm thick standard Black Butynol® rubber to all roof surfaces, gutters and fascias and walk out decks where membrane is to be overlaid with tiles or timber.

(b) Shall be 1.5mm thick Butynol® to all walk out decks.

6.2 Adhesives

Shall be as recommended by Ardex specially formulated for Butynol® rubber and suitable for the particular application and the relevant temperature and conditions applicable.

Generally Ardex WA98 adhesive (or WPM 09A) is used for substrate bonding.

Ardex seam primer shall be used in conjunction with Ardex seam tapes for all laps.

When conditions are experienced that are outside the temperature and/or moisture ranges recommended by the manufacturers for the above standard adhesives work will cease.

6.3 Seam Tapes

Shall be 50mm wide seam tape provided by Ardex.

6.4 Substrate Joint Tape

All Plywood joints shall be taped with a 25mm wide pressure sensitive Ardex Release tape.

7. Roof Deckings

Shall be 1.5mm Butynol® or 1mm with a protective covering for all deck surfaces.

All decks to which Butynol® is to be fixed shall be clean, smooth, dry and free from dirt, grit or sharp objects.

Deck substrates may be primed with 50/50 WA98 adhesive/solvent.

The Butynol® roofer shall co-operate with the other trades laying the decking to ensure that the final surface is in first class condition for the laying of the Butynol® rubber roofing.

The Butynol® roofer shall check the deck before laying any Butynol® to ensure that the surface is completely sound, screw fixed to specifications: screw heads flush, sheets spaced to provide for thermal movement or shock.

NZBC Acceptable Solution E2/AS1 limits the size of decks to 40m² as covered by the scope of Appraisal No. 436 (2011). Butynol® Roofing Membrane is suitable for use on decks larger than 40m². These decks are the subject of specific design.

Full Ardex specifications also available on Masterspec.

ARDEX Butynol®

BRANZ Appraised, E2/AS1 Acceptable Solution

8. Laying of Butynol® Roofing

It is the responsibility of the Applicator to ensure that the substrate surface to be covered by the Butynol® is in fit and proper condition, suitable for the laying of the material.

Tape all joints in substrate sheets with 25mm wide pressure sensitive tape approved by Ardex.

All Butynol® sheeting shall be laid out on the roof to "relax" the sheeting before fixing. A period of at least 20 minutes is usually required. Do not finally position sheeting with a tension exceeding 2%.

Apply adhesive to the substrate and the underside of the Butynol® rubber sheeting by brush, spray or an approved type roller at a spreading rate of generally not less than 2.5 square metres per litre. Leave to tack dry before bonding the two surfaces together.

Lay sheeting by drawing back halfway either longitudinally or transversely. Thoroughly roll or work over the surface of the sheet to exclude all air and to obtain a full bond.

All Butynol® shall be "lap bonded" as detailed below.

Bonding Laps with Ardex Seam Tape and Seam Primer

1. The top lap is positioned and the bottom sheet marked to indicate the edge of the top sheet.
2. The top sheet is folded back.
3. The Ardex Seam Primer is then applied to the Butynol® in the area marked on the bottom sheet and 50mm in from the edge on the top sheet. The Ardex Seam Primer is applied to the mating surfaces using a synthetic scrubbing pad. Scrubbing pads should be replaced as they become dirty. Allow the primer to become 'dry to the touch'.
4. Position and unroll the 50mm Ardex Seam Tape along the seam. The edge of the release paper should be aligned to the mark on the bottom membrane sheet.
5. Roll the length of the seam with the release paper still in place.
6. Remove the release paper from the Ardex Seam Tape by pulling at a 45° angle away from the seam. Keep the release paper low to the roof surface as it is removed.
7. Fold into place the primed edge of the top sheet.
8. Roll the completed seam.

9. Tiling Over Butynol®

To direct fix tiles to Butynol, ABA Optima two part adhesive should be used. Ensure the Butynol® surface is clean and dry before applying the adhesive. All laps must have seam tape.

Tiles may also be adhered to a removeable layer of Ardex DS60 to comply with (E2 7.3.1.1) with the ability to lift the top surface off when necessary.

(Refer Optima page 41)

10. Protection of Laid Butynol® Sheeting

The Butynol® roofing contractor shall ensure that his fixers only work on the Butynol® roofing with soft sole shoes.

The Butynol® roofer shall co-ordinate with the main contractor who shall ensure that any other trades who work over the completed roof wear soft sole shoes.

Upon completion of each area the roofer shall get the main contractor to inspect the area and the main contractor will sign off that the area was free from any defects or damage. It is then the responsibility of the main contractor to ensure the Butynol® roofing is in no way damaged by other trades.

11. Completion

On completion carefully and thoroughly clean off and remove all scraps and other rubbish from finished surfaces and leave in tidy order.

12. Extent of Work

Observe the foregoing specification and supply and lay Butynol® rubber sheeting to all roofs, decks, gutters and flashings as shown and detailed in the Ardex specification.

Failure to comply with the above specifications will result in all warranties being null and void.

LAYING SPECIFICATION

The Sub contractor for the work called for in this trade will be a Company or Person approved by Ardex.

The approved Applicator (hereafter called the Applicator) shall examine all drawings and provide for the flashing, caulking and sealing of all vents, stacks and pipes penetrating the roofing membrane. Also all flashings at walls, parapets, verges, gutters etc., unless otherwise instructed in the specifications.

The surface to which Butynol® is to be fixed shall be clean, smooth, dry and free from sawdust, grit or sharp objects. Membrane laying shall not start until defects have been corrected.

To avoid staining care should be taken to avoid water runoff from copper downpipes or guttering on to light coloured Butynol®.

When CCA plywood is used in conjunction with a light coloured membrane it is advisable to prime any plywood that will not be covered the same day.

It is the responsibility of the Applicator to ensure that the surface to be covered by the Butynol® is in fit and proper condition, suitable in all respects for the laying of the material.

On completion the Applicator will provide the owner with a Workmanship Warranty and obtain from Ardex a Materials Warranty.

Failure to comply with the above specifications will result in all warranties being null and void.

LAYING THE BUTYNOL®

Before applying the Butynol®, it shall be unrolled for twenty minutes to relieve stresses induced by manufacture and storage. The Butynol® sheet shall be set out in the exact position in which it will be finally required and while it is held in place, it shall be folded back lengthwise to expose half the underside. To the now exposed underside and the area of roof also left exposed, apply an even coat of WA98 Adhesive or WPM 09A (solvent free). When the adhesive has become touch dry, work the sheet back into its original position avoiding wrinkles and the inclusion of air bubbles.

Repeat the process with the other half of the sheet and when completed, roll the whole sheet with hand press rollers or the like.

When applying the next sheet, it shall be lapped over the first sheet by 50mm. All turn ups and downs shall be neatly formed and cut to a straight line if required.

Butynol shall not be laid under tension.

When the whole area has been covered or as work progresses, the applicator has to seal the laps.

BUTYNOL® LAYING METHOD

STEP 1

Accurately place sheet. Mark spacing with chalk line.

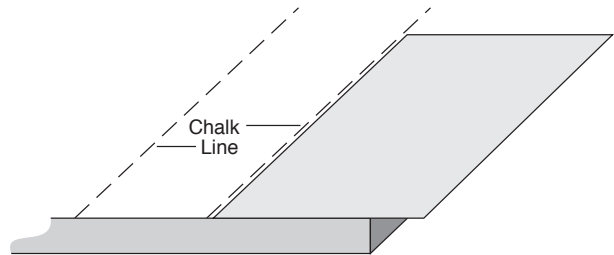

STEP 2

Fold back half sheet. Apply adhesive to both faces.

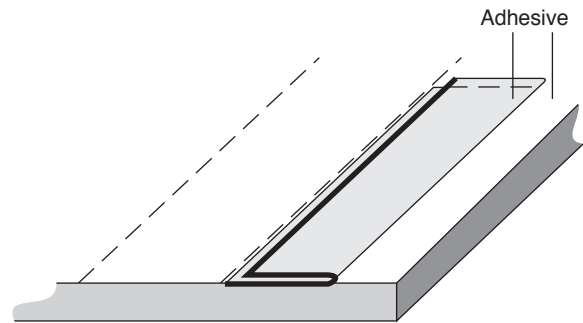

STEP 3

After flash off, fold membrane into place. Roll thoroughly.

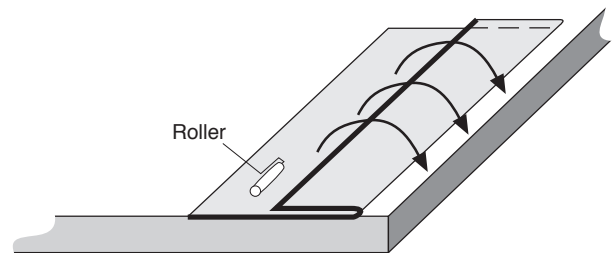

STEP 4

Treat 2nd half of Butynol® similarly.

ARDEX Butynol®

BRANZ Appraised, E2/AS1 Acceptable Solution

EXTERNAL CORNERS

To comply with Acceptable Solution E2/AS1 Figure 57.

STEP 1

Bond 100mm flashing to corner as shown.

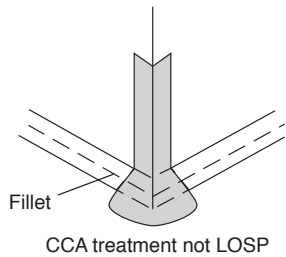

STEP 2

Bond Butynol® to deck and up wall 150mm minimum. Cut sheet from corner at 45° as shown.

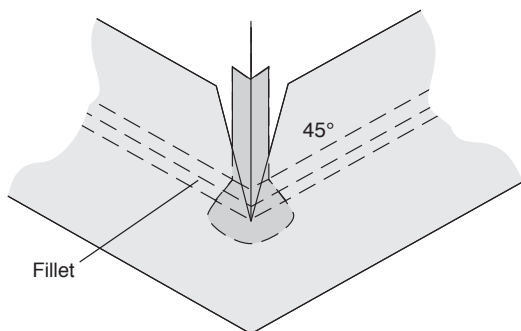

STEP 3

Cover corner point with layer of detail tape.

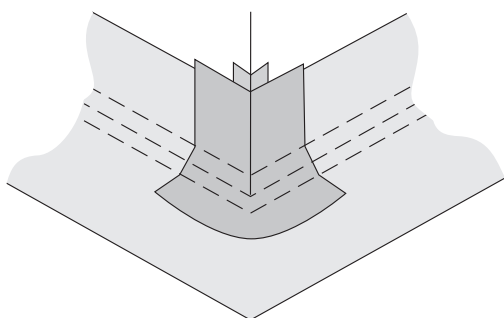

NOTE: Fillets must be used on all internal corners.

FLASHING - EXISTING PIPE

STEP 1

Under flash pipe with 100mm Butynol® flashing tape.

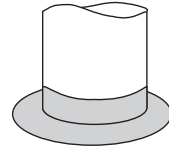

STEP 2

Bond Butynol® to 100mm past pipe. N.B. When flashing black Butynol® use Butynol® or detail tape.

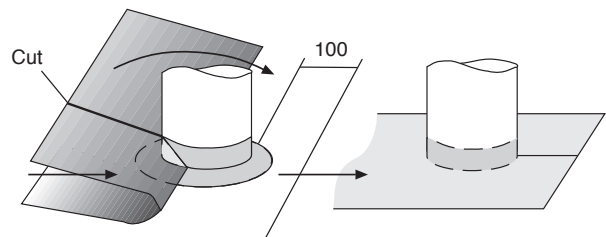

STEP 3

Bond continuation of Butynol® to overlap base sheet and beyond pipe 100mm.

Cut a smooth round hole 20mm smaller than diameter of penetration.

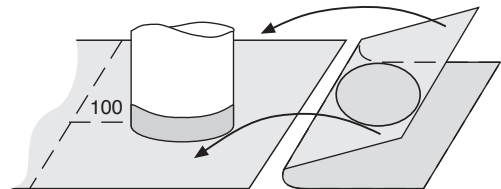

STEP 4

Apply collar of detail tape or Butynol® cover strip. DO NOT STRETCH STRIP.

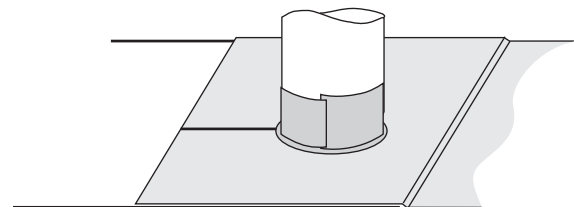

N.B. Flashing tape MUST NOT be left exposed. Cover strip must be Butynol®. When detail tape is used a cover strip of Butynol® is not required.

FLASHING - NEW PIPE

STEP 1

Cut smaller diameter hole than pipe.

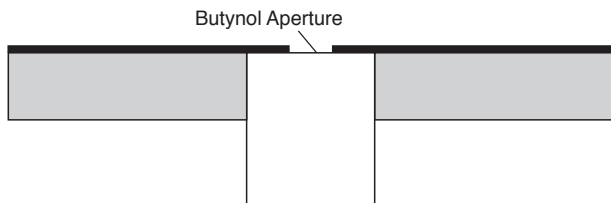

STEP 2

Pipe is raised through smaller diameter hole in Butynol®, forcing edge upwards to create upstand.

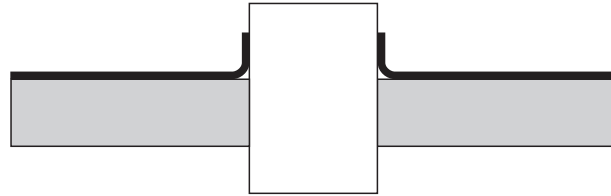

STEP 3

Pull pipe down to eliminate void.

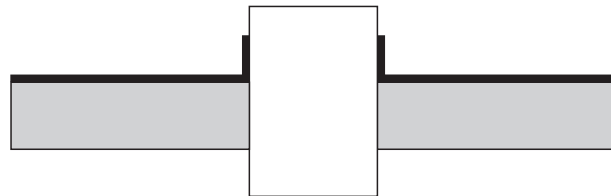

STEP 4

After pulling pipe down approximately 1cm to sharpen corner, tape upstanding Butynol® to pipe using seam primer and detail tape.

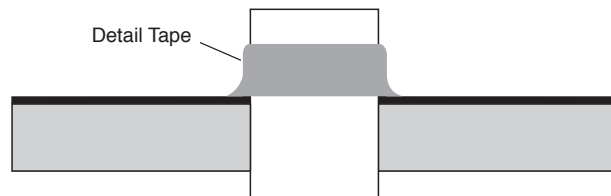

N.B. If flashing tape is used it MUST NOT be left exposed. A cover strip of Butynol® must be applied over the flashing tape to finish.

INTERNAL CORNERS FOR RAINHEADS and areas where a pig's ear cannot be used.

STEP 1

Apply Flashing Tape over Rainhead and Plywood.

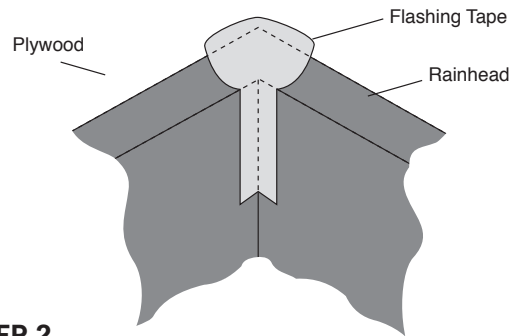

STEP 2

Run Seam Tape along all four vertical sides of Rainhead.

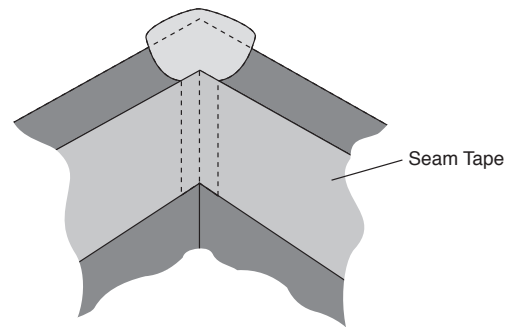

STEP 3

Cut Butynol® sheet to fit into corners.

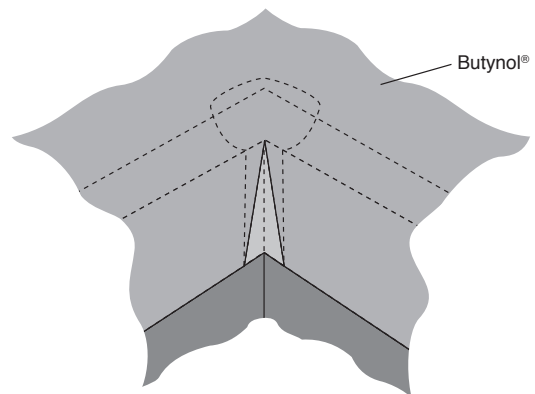

STEP 4

Cover corner point with layer of detail tape.

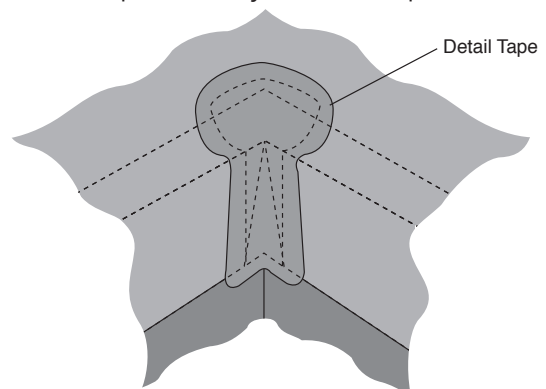

ARDEX Butynol®

BRANZ Appraised, E2/AS1 Acceptable Solution

BONDING THE LAPS

Seam tape and seam primer must be used for all Butynol® joints.

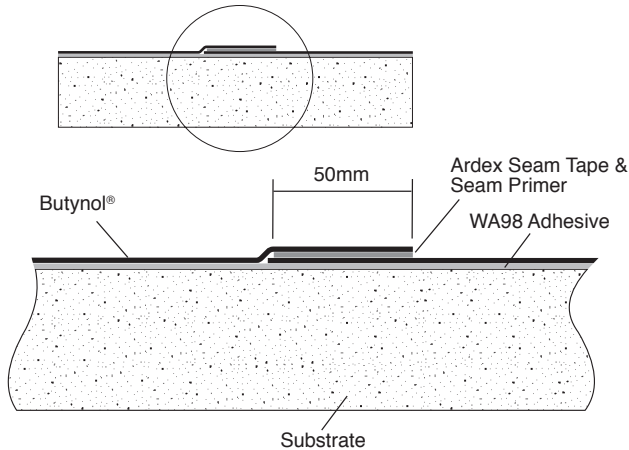

1. The top lap is positioned and the bottom sheet marked to indicate the edge of the top sheet.
2. The top sheet is folded back.
3. The Ardex Seam Primer is then applied to the Butynol® in the area marked on the bottom sheet and 50mm in from the edge on the top sheet. The Ardex Seam Primer is applied to the mating surfaces using a synthetic scrubbing pad. Scrubbing pads should be replaced as they become dirty. Allow the primer to become 'touch dry'.
4. Position and unroll the 50mm Ardex Seam Tape along the seam. The edge of the seam tape should be aligned to the mark on the bottom membrane sheet. The see-through backing film makes this very simple.
5. Roll the length of the seam with backing film still in place.
6. Remove the backing film from the Ardex Seam Tape by pulling at a 45° angle away from the seam. Keep the backing film low to the roof surface as it is removed.
7. Fold into place the primed edge of the top sheet.
8. Roll the completed seam.

FORMING LAPS FOR GUTTERS

Laps are most important in gutter work and should be formed using Ardex seam tape and seam primer.

All internal boxed gutters can be easily formed to any shape or size using Butynol® over any specified substrate.

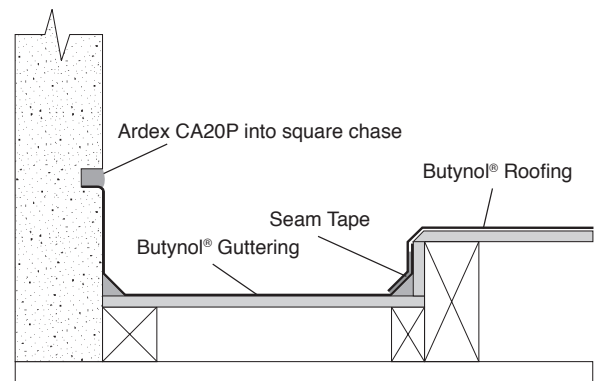

FLUE FLASHING

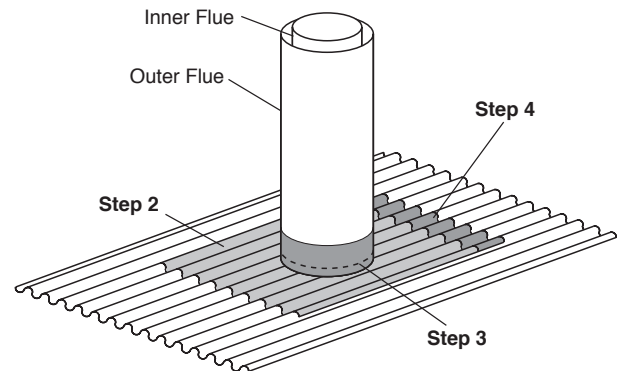

Step 1

Measure Butynol® to suit size of pipe. Cut a smooth round hole at least 20mm smaller than diameter at flue penetration.

Step 2

Fix Butynol® Flashing onto roofing with WA 98 adhesive ensuring membrane is relaxed into roofing profile.

Step 3

Apply collar of Detail Tape sealed with Seam Primer onto 20mm Butynol® upstand.

Step 4

Apply flashing strip of Detail Tape sealed with Seam Primer onto Butynol® top edge and roofing ensuring feather edge is on the upside.

FLASHING INTO CONCRETE WALLS

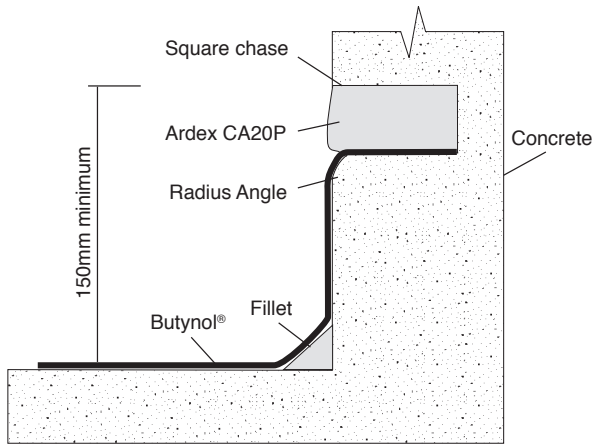

Butynol® is glued into square chase and finished with Butynol® Sealant.

RECOMMENDED BATTEN PROFILE DETAIL

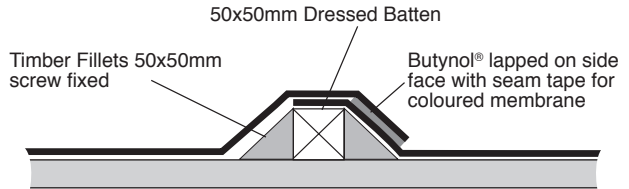

Battens arranged to suit plywood sheet sizes or visual effects

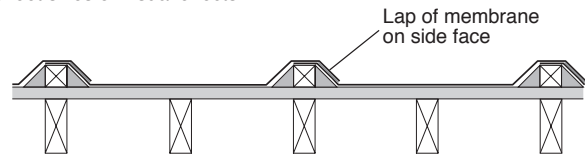

Suggested 1200mm centres

Example of a 1400mm sheet of Ardex Butynol® dressed over battens at 1200mm centres

Note: Treatment for battens must be H3.2 (CCA) only. Not LOSP treated.

BOXED GUTTER AND PARAPET DOWNTURN

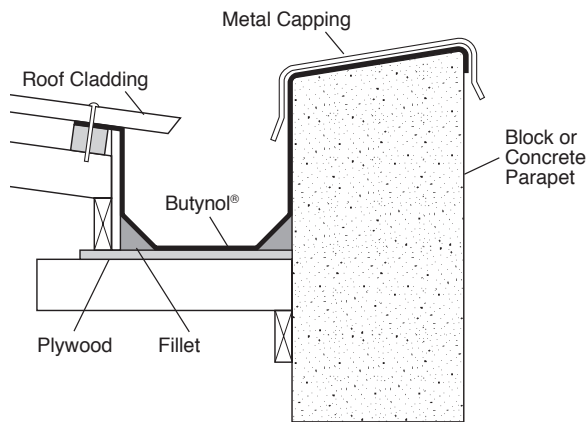

INTERNAL CORNERS

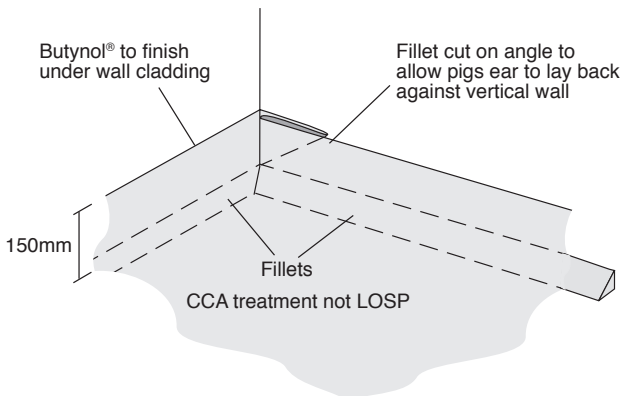

Without cutting Butynol® simply fold a 'pig's ear' corner as shown. The angle fold should be behind the main sheet.

NOTE: Fillets must be used on all internal corners.

INTERNAL GUTTER

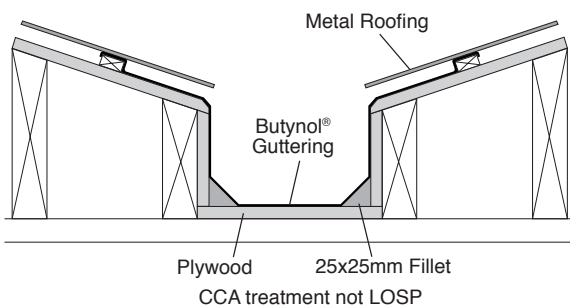

TAPING SUBSTRATE SHEETS

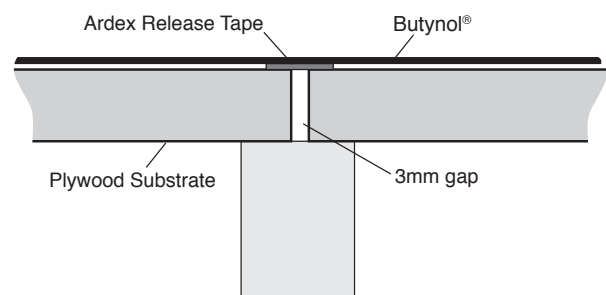

All joints between substrate sheets of Ply should be taped to prevent stressing of the Butynol® in case of marked timber movement.

ARDEX Butynol®

BRANZ Appraised, E2/AS1 Acceptable Solution

ONE WAY SUBSTRATE VENTILATOR

PVC or Aluminium

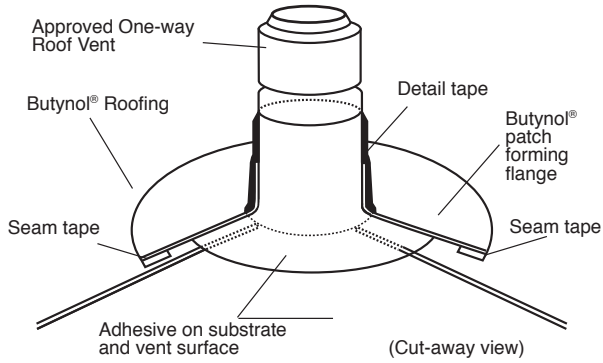

Vent installed over intersection of vent tapes on concrete substrate

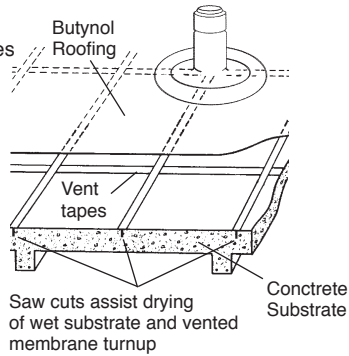

Vent installed over intersection of 3mm gap between Ply substrate sheets.

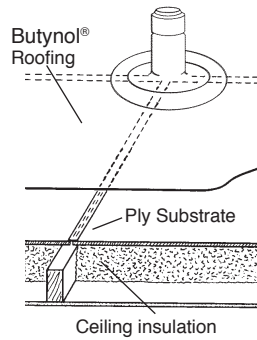

LO RISE ROOF VENT



TWO METHODS FOR FINISHING OVER A GUTTER

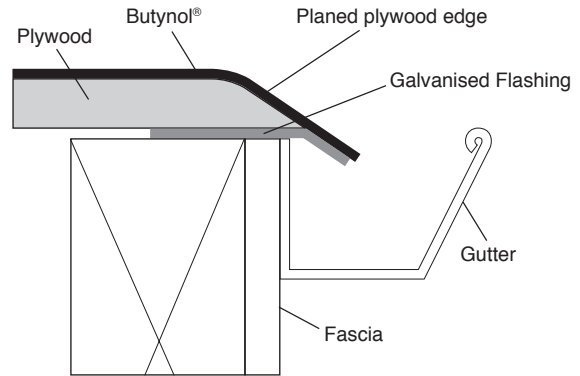
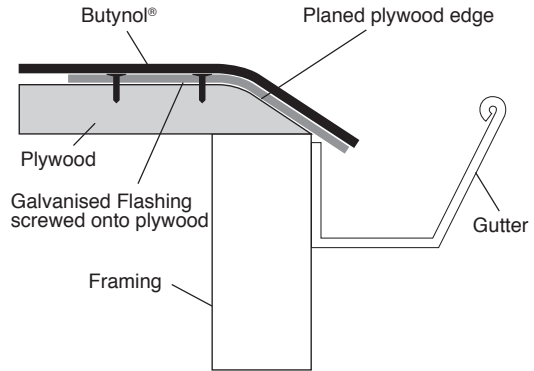

ROOFING PENETRATION IN MEMBRANE

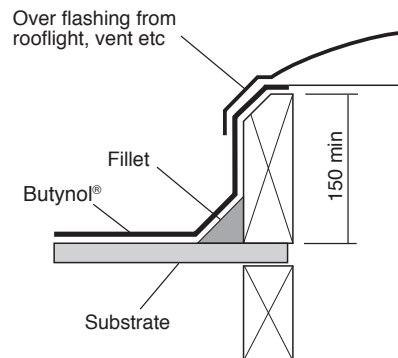

NOTE: 1 For maximum penetration size of 1200x1200mm
2 External corners to be formed as shown

SCUPPER OUTLET

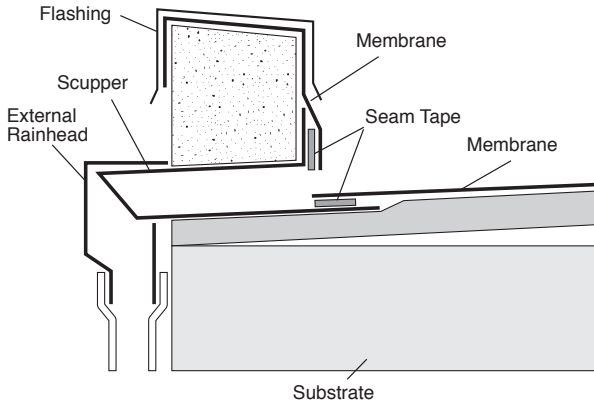

BUTYNOL®/CORRUGATE PITCH CHANGE JUNCTION

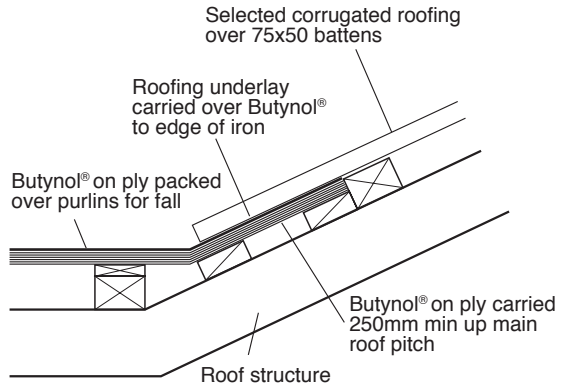

INTERNAL ROOF DRAIN (NZBC E2/AS1 Approved)

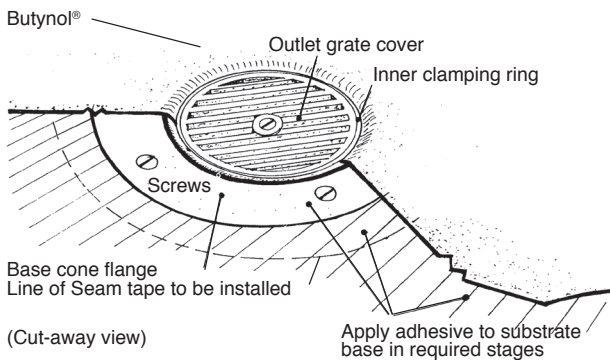
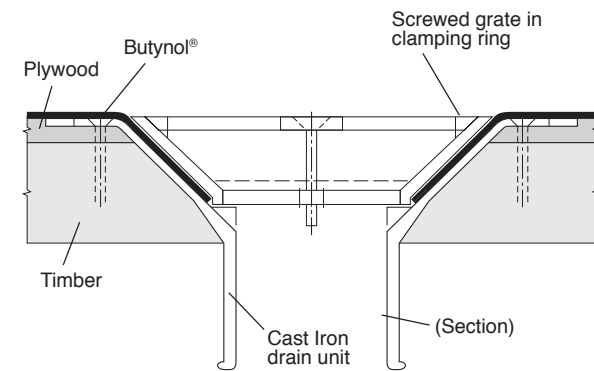

BUTYNOL® LAPPING OVER METAL FLASHING

25mm polyethylene release tape over metal edge and screw/clout heads. Fixing @ 100mm centres

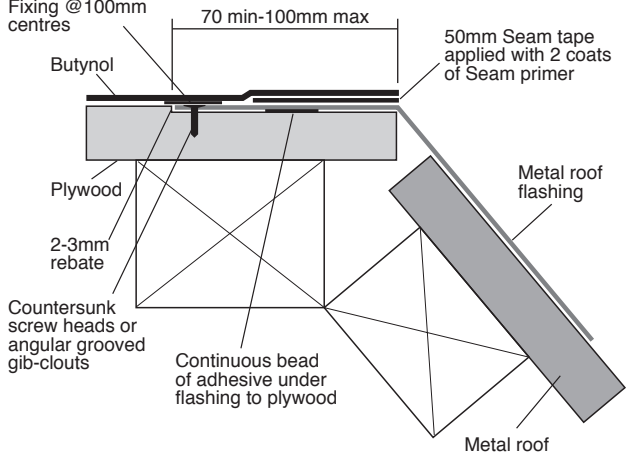

Where Seam tape is to be used **no** silicone sealant should be used when installing flashing. If silicone is present remove completely with solvent.

BUTYNOL® FLUSH FINISH TO METAL EDGE

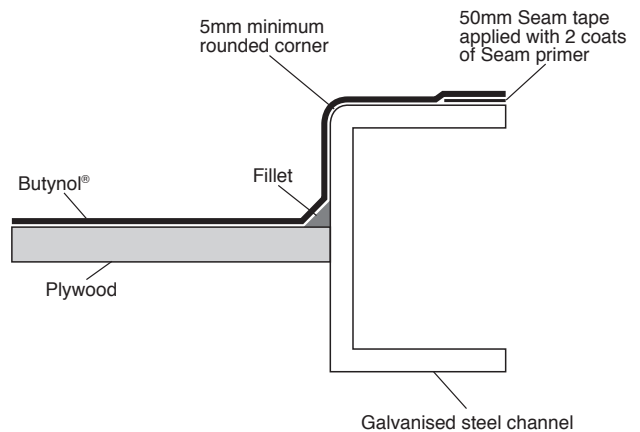

ARDEX Butynol®

BRANZ Appraised, E2/AS1 Acceptable Solution

RAINWATER HEAD AND SCUPPER OPENING IN MEMBRANE USING ARDEX BT 300 OR BT 301 SCUPPER

Deck outlet

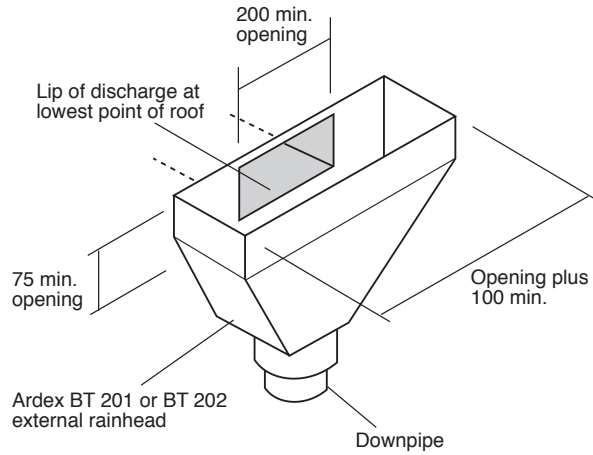

Overflow

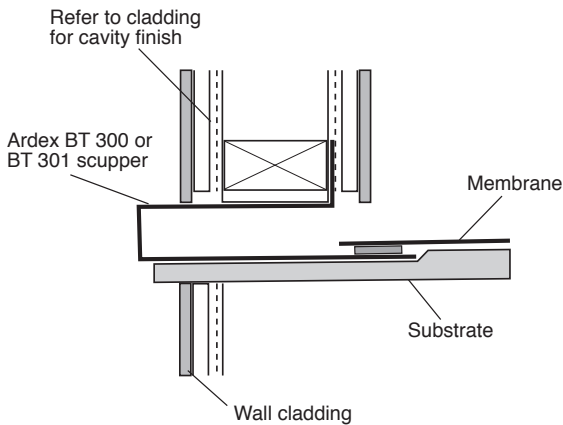

Air Conditioning/Plant Fixing Detail

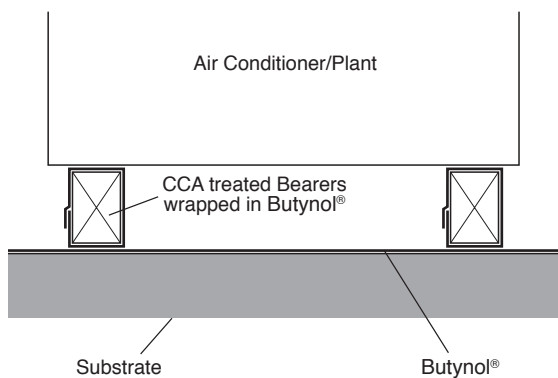

GUTTERS AND OUTLETS IN MEMBRANE

Edge gutter

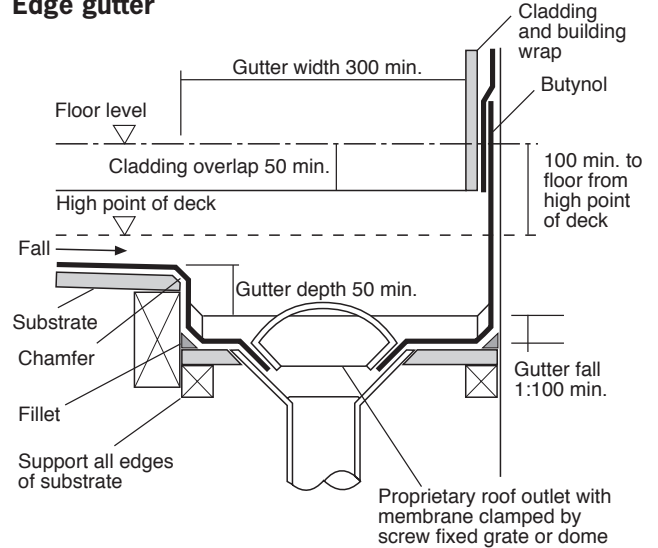

Central gutter

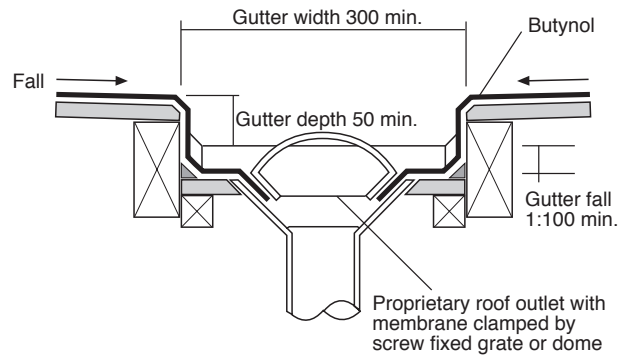

Aluminium Pressure Bar Seal

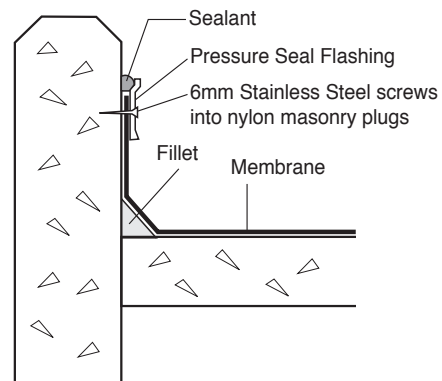

FALLS IN BUTYNOL® ROOFS AND DECKS

Roof

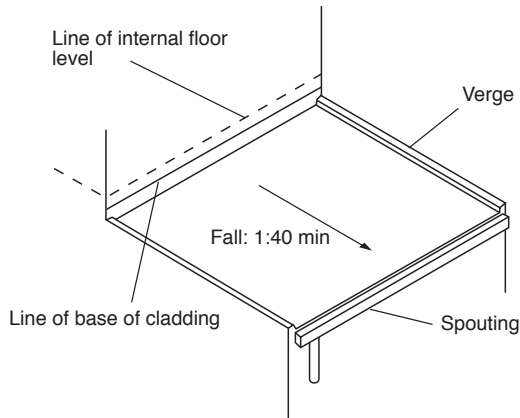

Deck

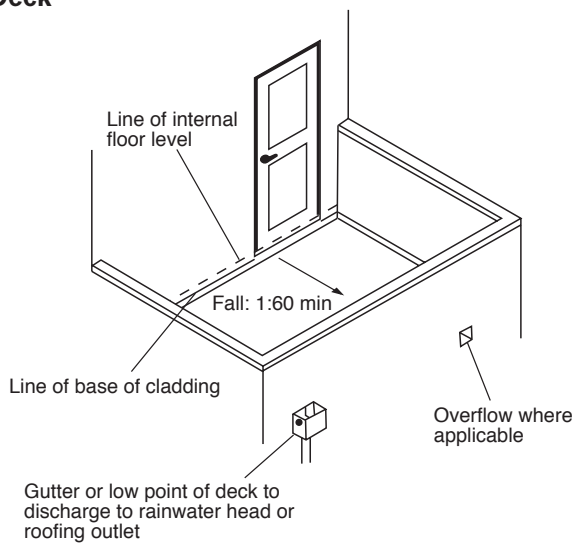

EAVE AND VERGES IN BUTYNOL®

Eave

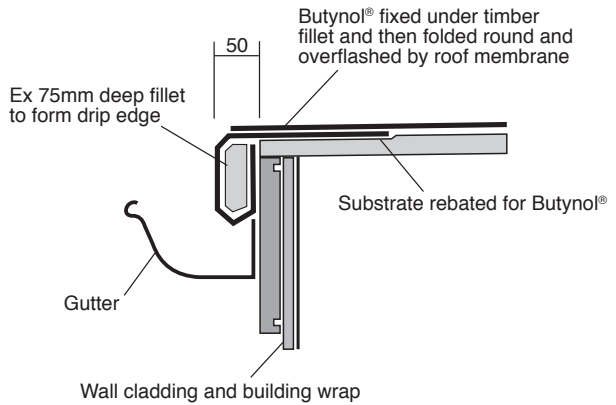

Verges

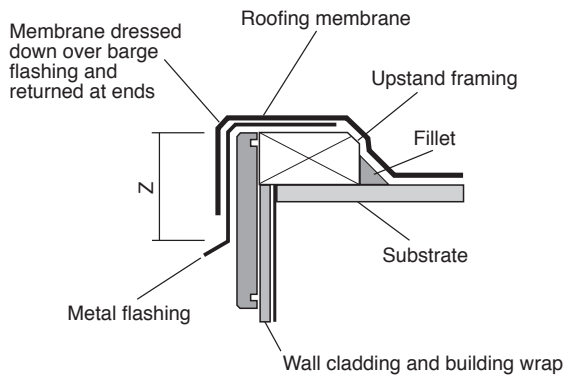
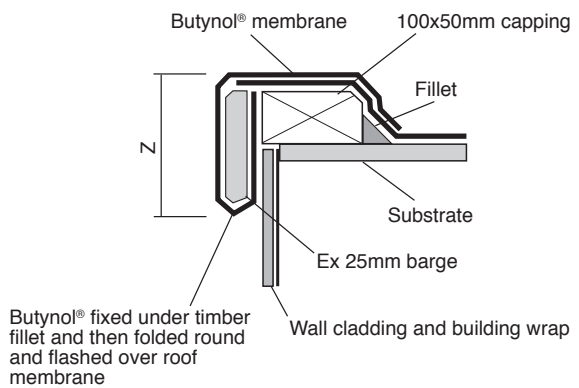

NOTE: Z = variable according to wind zone

ARDEX Butynol®

BRANZ Appraised, E2/AS1 Acceptable Solution

JUNCTIONS WITH WALLS FOR BUTYNOL®

Direct fix threshold at wall

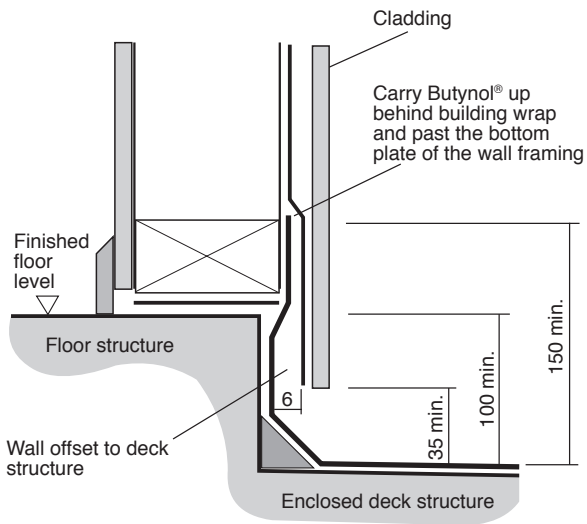

Direct fix threshold at opening

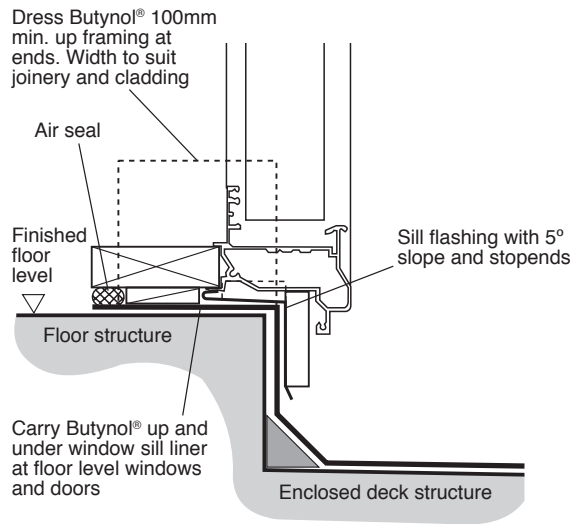

Cavity threshold at wall

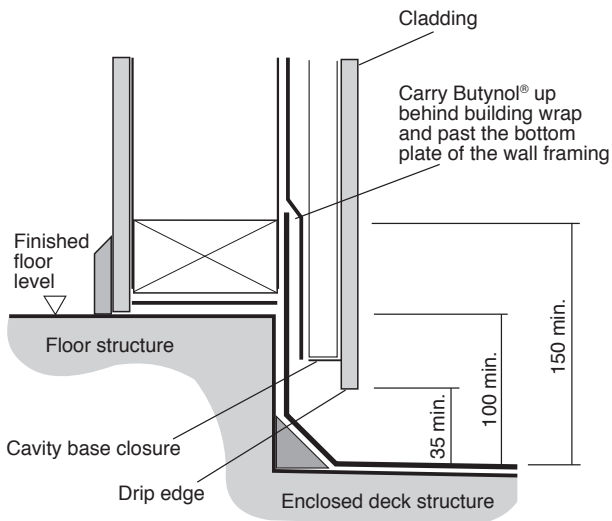

Alternative threshold at opening

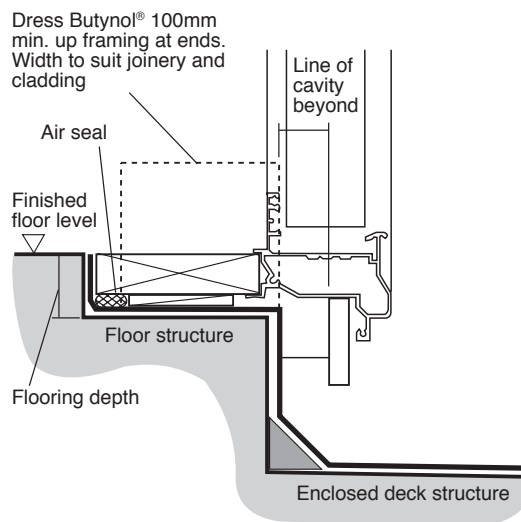

- NOTE: 1 Internal corners to be formed as shown on page 26
 2 Dimensions are shown to Butynol®. However, where there is an additional material applied over the Butynol® all dimensions shall apply to the highest level of the wearing surface

LOOSE LAID APPLICATION OF BUTYNOL® ROOFING

Materials used shall be as previously specified. When the surface is suitably prepared a large fully vulcanised Butynol sheet or sheets can be unrolled and spread over the prepared area and allowed to remain in this position for approximately one hour to relieve stresses induced by manufacture and storage. If necessary for ease of handling, these sheets can be supplied in varying sizes and vulcanised on site using an Ardex vulcanising machine or using seam tape with seam primer.

The Butynol® sheet shall be set out in the exact position in which it will be finally required and whilst it is held firmly in place it shall be folded back at least one metre from the roof's surrounding parapet or wall to allow the application of adhesive to that area of the exposed substrate.

WA98 adhesive may be applied to the substrate and the corresponding area of Butynol® sheeting which may then, when the adhesive is touch dry, be worked back into its required position avoiding wrinkles and the inclusion of air bubbles.

Upon completion of the detail work, parapets, drains and rainheads etc a layer of rounded gravel 30-40mm should be applied up to 50mm deep, over a layer of Geo Textile Fabric for protection of the Butynol® sheet.

Care must be taken at outlets to ensure the ballast cannot enter or cause a blockage that prevents rainwater from leaving the roof area. Maintenance paths should be created to air-conditioning or roof plant with concrete tiles.

Effects on the membrane in areas of high wind can be eliminated by stabilising the ballast with cement. Dry cement should be broadcast over the 30-40mm gravel with a broad mouth shovel and left to hydrate or lightly sprayed with water to set off.

If possible a water test should be carried out prior to the application of ballast.

Note: Minimum pitch 2.0° to comply.

Refer NZBC Clause E@/AS1 External Moisture 8.5.1 (a).

Butynol® can be laid with zero pitch if compliance can be obtained. Lap may be welded in factory or on site if required.

TYPICAL BALLASTED/GARDEN ROOF DETAIL

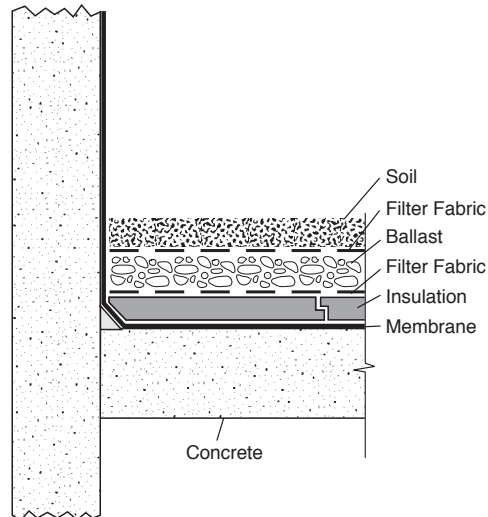

SCUPPER ROOF OUTLET

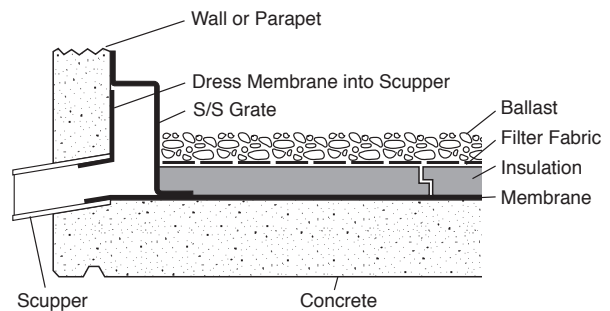

SCUPPER ROOF OUTLET & GRAVEL RETAINER

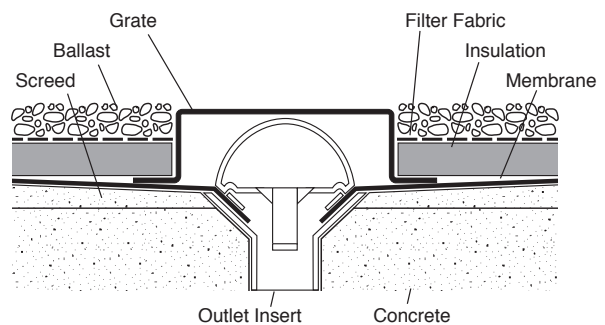



ARDEX ECO Butynol®

Fibre-backed Rubber Membrane System

BRANZ Appraised

E2/AS1 Acceptable Solution

DISCLAIMER The technical details, recommendations and other information contained in this data sheet are given in good faith and represent the best of our knowledge and experience at the time of printing. It is your responsibility to ensure that our products are used and handled correctly and in accordance with any applicable New Zealand Standard, our instructions and recommendations and only for the uses they are intended. We also reserve the right to update information without prior notice to you to reflect our ongoing research and development program. Country specific recommendations, depending on local standards, codes of practice, building regulations or industry guidelines, may effect specific installation recommendations. The supply of our products and services is also subject to certain terms, warranties and exclusions, which may have already been disclosed to you in prior dealings or are otherwise available to you on request. You should make yourself familiar with them.

ARDEX ECO Butynol®

Fibre-backed Rubber Membrane System



ECO BUTYNOL® SYSTEM SPECIFICATION

Butynol® synthetic rubber with properties which resist ageing from heat, sunlight and ozone. Polypropylene filaments are welded on to one side of the membrane for better wetting by water based adhesives. It has excellent gas impermeability and toughness and remains flexible at low temperatures. Eco Butynol® is marketed by Ardex as a warranted roofing and tanking product using solvent free water based adhesive, Ardex WPM 09A and catalyst Ardex WPM 09C and fixed by their trained and experienced approved Applicators.

BUTYNOL® MATERIAL SPECIFICATIONS

(For the rubber part) Our requirements for long term warranty necessitate that the rubber part of Eco Butynol® meets these typical technical requirements:

Specific Gravity to ASTM D297	1.20±0.05
Hardness IRHD to ASTM D1415	65±5
Tensile Strength to ASTM D412	8.3 MPa min
Modulus at 300% elongation to ASTM D412	4.15 MPa min
Elongation at break to ASTM D412	300% min
Heat Ageing (7 days at 115°C)	
Tensile Retention to ASTM D412	70% min
Elongation Retention to ASTM D412	70% min
Tear Strength to ASTM D624	26kN/m
Ozone Resistance to ASTM D1149	No visible cracks (7 days at 40°C in 50pphm ozone)
Water Absorption to ASTM D471	1.65% (by mass)
Water Permeability to ASTM E96-92	0.72% (by volume)
Vapour Flow Resistance	12414 (MNs/g)
Vapour Flow Rate	0.013 (g/m ² d)

Note: Interesting comparable figures for water permeability are –

Polythene 156, Asphalt 1830, P.V.C. 4900

K Values on 1mm Eco Butynol® sheeting

K Value (Thermal Conductivity) 7.4 x 10³Cal/cm/sec/deg C

Conductivity Data on 1mm Eco Butynol® sheeting

Resistance/m² Ω /m² = 0.6816 on 9.3 volts

ECO BUTYNOL® GAUGES

Standard 1.0mm – For roofs, gutters and decks with protection.

1.2mm – For roofs

1.5mm – For roofs and walk out decks

2.25mm – Heavy Duty

Factory welded panels in all gauges can be custom made.

PACKAGING

Eco Butynol® is packaged in rolls of nominal 1.4m width and 17.86m long. Each roll is packed in polythene wrapper trademarked Eco Butynol® with thickness identified. Coverage 25m² except 2.25mm gauge which is 12m².

Gauges available are:

1.0mm black. Weight: nominal 30kg

1.5mm black. Weight: nominal 45kg

2.25mm black. Weight: nominal 32kg

1.2mm dove grey. Weight: nominal 32kg

1.5mm all colours. Weight: nominal 47kg

ADHESIVE

Ardex WPM 09A Adhesive is specially formulated for all Eco Butynol® applications. Supplied in 15L plastic pails.

BUTYNOL® SEALANT

Available in tubes for caulking guns.

SEAM PRIMER

Seam Primer is specially formulated for use with Seam Tape. It is solvent based. Seam Primer makes up less than 5% of the average roofing job. Applied with scrubber pads. Available in 4 and 1 litre cans.

SEAM TAPE

Recommended for all Butynol® laps.

Supplied by Ardex in 50mm x 30.5m rolls (6 to a carton).

DETAIL TAPE (uncured)

A malleable exterior tape for flashing exterior corners etc. 150mm x 30.5m rolls.

FLASHING TAPE

A malleable tape for moulding in gussets, pipe flashings and awkward situations. Supplied in 100mm x 5m rolls. Flashing tape must not be left exposed. A cover strip of Butynol® or detail tape must be applied over flashing tape to finish.

ADHESIVE AND CATALYST FOR USE WITH ECO BUTYNOL®

Ardex WPM 09A The Standard contact brushing, spray grade and rolling adhesive for fixing to the substrate. (Pitch 5° and above)

Ardex WPM 09C Catalyst to be used in conjunction with Ardex WPM 09A. Improves bond, creates instant grab

NOTES

1. As new substrate materials continually appear on the market, consult Ardex for approval of their use with Eco Butynol®.
2. For all lap joints, Ardex Seam Tape and Seam Primer must be used on all joints.
3. Do not use in temperatures less than 6°C.

IMPORTANT NOTE

For information on the following please refer to Ardex Butynol® section

SUBSTRATE VENTILATION

PLYWOOD TREATMENT

DURABILITY

EXTERNAL MOISTURE

BUILDING TO NZBC ACCEPTABLE SOLUTION E2/AS1

CLEANING WEATHERED ECO BUTYNOL®

DAMP AND WEATHERPROOFING

PAINTING OVER ECO BUTYNOL®

FIRE RATING

PRODUCT WARRANTY

WORKMANSHIP

SUBSTRATE SPECIFICATION (Plywood)

SUBSTRATE SPECIFICATION (Concrete)

TYPICAL ARCHITECTURAL SPECIFICATION

LAYING SPECIFICATION

LAYING THE ECO BUTYNOL®

LOOSE LAID APPLICATION

Note that detail drawings in the Ardex Butynol® section apply to Eco Butynol® except solvent free WPM 09A adhesive is to be used.





BRANZ Appraised

Appraisal No.727 [2011]

BRANZ Appraisals

Technical Assessments of products
for building and construction

**BRANZ
APPRAISAL
No. 727 (2011)**

ARDEX UNDERTILE SHEET MEMBRANE (WPM 750)

Ardex New Zealand Limited
P O Box 19549
Christchurch

Tel: 03 384 3029
Fax: 03 384 9779
Web: www.butynol.co.nz



BRANZ

BRANZ Limited
Private Bag 50 908
Porirua City
New Zealand

Tel: +64 4 237 1170
Fax: +64 4 237 1171
www.branz.co.nz



Product

1.1 Ardex Undertile Sheet Membrane (WPM 750) is a synthetic rubber membrane for use in internal wet areas to be covered with ceramic or stone tiles.



Scope

2.1 Ardex Undertile Sheet Membrane (WPM 750) has been appraised for use as waterproofing membrane for internal wet areas of buildings, within the following scope:

- on floor substrates of concrete, plywood, compressed fibre cement sheet and fibre cement sheet tile underlay, and on wall substrates of concrete, concrete masonry, wet area fibre cement sheet lining systems and wet area plasterboard lining systems; and,
- when protected from physical damage by ceramic or stone tile finishes; and,
- where floors are designed and constructed such that deflections do not exceed 1/360th of the span.

2.2 The use of Ardex Undertile Sheet Membrane (WPM 750) on concrete slabs where hydrostatic or vapour pressure is present from below is outside the scope of this Appraisal.

2.3 Movement and control joints in the substrate must be carried through to the tile finish. The design and construction of the substrate and movement and control joints is specific to each building, and therefore the responsibility of the building designer and building contractor and is outside the scope of this Appraisal.

2.4 The ceramic or stone tile finishes are outside the scope of this Appraisal.

2.5 The membrane must be installed by trained applicators, approved by Ardex New Zealand Limited.

Building Regulations

New Zealand Building Code (NZBC)

3.1 In the opinion of BRANZ, Ardex Undertile Sheet Membrane (WPM 750) if designed, used, installed and maintained in accordance with the statements and conditions of this Appraisal, will meet the following provisions of the NZBC:

Clause B2 DURABILITY: Performance B2.3.1 (b) 15 years. Ardex Undertile Sheet Membrane (WPM 750) meets this requirement. See Paragraph 9.1.

Clause E3 INTERNAL MOISTURE: Performance E3.3.6. Interior wet area floors and walls incorporating Ardex Undertile Sheet Membrane (WPM 750) will meet this requirement. See Paragraphs 11.1- 11.6.

Clause F2 HAZARDOUS BUILDING MATERIALS: Performance F2.3.1. Ardex Undertile Sheet Membrane (WPM 750) meets this requirement and will not present a health hazard to people.

This is an Appraisal of an **Alternative Solution** in terms of New Zealand Building Code compliance.

Technical Specification

4.1 Materials supplied by Ardex New Zealand Limited are as follows:

Ardex Undertile Sheet Membrane (WPM 750)

- A single ply synthetic rubber membrane with polypropylene filaments welded to both sides, this enables better wetting out by water based adhesives. It is supplied as a 1.0mm thick, 1.4m wide x 20m long roll.

Ardex WPM 09A – Solvent Free Adhesive

- A solvent free adhesive for bonding Undertile Butynol (WPM 750) to all substrates. It is supplied in 15l containers.

Ardex WPM 09C – Catalyst

- A solvent free catalyst for Ardex WPM 09A Solvent free Adhesive to speed up adhesive cure in adverse conditions. It is supplied in 5l containers.

Ardex Clamp Waste Outlet

- A floor waste outlet designed to clamp the membrane and supplied as part of the system. The plumbing aspects of the floor waste outlet has not been assessed by BRANZ and are outside the scope of this Appraisal.

Handling and Storage

5.1 All materials must be stored inside, up off concrete floors, in dry conditions, out of direct sunlight and out of freezing conditions.

Technical Literature

6.1 Refer to the Appraisals listing on the BRANZ website for details of the current Technical Literature for the Ardex Undertile Sheet Membrane (WPM 750). The Technical Literature must be read in conjunction with this Appraisal. All aspects of design, use, installation and maintenance contained in the Technical Literature and within the scope of this Appraisal must be followed.

Design Information

General

7.1 Ardex Undertile Sheet Membrane (WPM 750) is for use in buildings where an impervious waterproof membrane is required to floors and walls to prevent damage to building elements and adjoining areas.

7.2 The membrane must be protected from physical damage by the application of ceramic or stone tile finishes.

7.3 Movement and control joints may be required depending on the shape and size of the building or room, and the tile finish specified. Design guidelines can be found in the BRANZ “Good Practice Guide Tiling”.

7.4 Timber framing systems must comply with NZS 3604, or where specific engineering design is used, the framing shall be of at least equivalent stiffness to the framing provisions of NZS 3604, or comply with the serviceability criteria of AS/NZS 1170. Timber framing systems supporting the substrates must be constructed such that deflections do not exceed 1/360th of the span. Where NZS 3604 is used, the allowable joist spans given in Table 7.1 shall be reduced by 20%. In all cases framing

must be provided so that the maximum span of the substrate as specified by the substrate manufacturer is met and all sheet edges are fully supported.

7.5 Ardex Undertile Sheet Membrane (WPM 750) must not be used to bridge or cover over existing expansion, control, construction, cold or saw cut joints.

Substrates

Plywood

8.1 Plywood must be a minimum of 17 mm thick complying with AS/NZS 2269, CD Grade Structural with sanded C face upwards and treated to H3 (CCA treated). LOSP treated plywood must not be used. The plywood must be supported with dwangs or framing with a maximum span of 400 mm in each direction and fixed with 10 g x 50 mm stainless steel countersunk head screws at 150 mm centres on the edges and 200 mm through the body of the sheets.

Fibre Cement Compressed Sheet / Fibre Cement Sheet Tile Underlay

8.2 Fibre cement compressed sheet must be manufactured to comply with the requirements of AS 2908.2 and must be specified by the manufacturer as being suitable for use as a wet area substrate. Fibre cement sheet tile underlay must be suitable for use in internal wet areas. Installation must be in accordance with the instructions of the manufacturer.

Concrete and Concrete Masonry

8.3 Concrete and concrete masonry substrates must be to a specific engineering design meeting the requirements of the NZBC, such as concrete construction to NZS 3101, concrete slab-on-ground to NZS 3604, and concrete masonry to NZS 4229 and NZS 4230.

Wet Area Wall Linings

8.4 Plasterboard wall linings must be manufactured to comply with AS/NZS 2588 and be suitable for use in internal wet areas.

8.5 Fibre cement sheet manufactured to comply with the requirements of AS 2908.2 and must be specified by the manufacturer as being suitable for use in wet areas.

Durability

Serviceable Life

9.1 Ardex Undertile Sheet Membrane (WPM 750), when subjected to normal conditions of environment and use, is expected to have a serviceable life of at least 15 years and be compatible with ceramic or stone tile finishes with a design service life of 15-25 years.

Maintenance

10.1 No maintenance of the membranes will be required provided significant substrate movement does not occur and the tile finish remains intact. Regular checks must be made of the tiled areas to ensure they are sound and will not allow moisture to penetrate. Any cracks or damage must be repaired immediately by repairing the tiles, grouts and sealants.

10.2 In the event of damage to the membrane, the tiling must be removed and the membrane repaired by removing the damaged portion and applying a patch as for new work.

10.3 Drainage outlets must be maintained to operate effectively, and ceramic or stone tile finishes must be kept clean.

Internal Moisture

11.1 Ardex Undertile Sheet Membrane (WPM 750) is impervious to water and when appropriately designed and installed will avoid the likelihood of water penetrating behind linings or entering concealed spaces.

11.2 Ardex Undertile Sheet Membrane (WPM 750) is suitable for use to contain accidental overflow to meet NZBC Clause E3.3.2. A means of Code Compliance for overflow is given in NZBC Acceptable Solution E3/AS1 Paragraph 2.

11.3 Surfaces must be finished with ceramic or stone tile finishes. A means of Code Compliance to NZBC Clause E3.3.3 and E3.3.4 is given in NZBC Acceptable Solution E3/AS1 Paragraph 3.1.1 (b), 3.1.2 (b) and 3.3.1 (b).

11.4 Falls in showers and shower areas must be a minimum of 1 in 50. In unenclosed showers, falls must extend a minimum of 1500 mm out from the shower rose. Floor wastes must be provided and the floor must fall to the outlet.

11.5 The waterproofing membrane must completely cover shower bases, and for unenclosed showers it must extend a minimum of 1500 mm out from the shower rose. Further design guidance on waterproofing wet areas, including waterproofing walls and junctions can be obtained from AS 3740, BRANZ "Good Practice Guide Tiling", and flooring and wallboard manufacturers.

11.6 Where water resistant wall finishes such as prefinished sheet materials are used, they must flash over the membrane a minimum of 30mm.

Installation Information

Installation Skill Level Requirement

12.1 Installation of the membrane must be completed by Ardex New Zealand Limited trained and approved applicators that have experience in the application of waterproofing membranes and understand waterproofing principles.

12.2 Installation of substrates must be completed by tradespersons with an understanding of internal wet area construction, in accordance with instructions given within the Ardex New Zealand Limited Technical Literature and this Appraisal.

Preparation of Substrates

13.1 Substrates must be dry, clean and stable, with surfaces that are even and free from nibs, sharp edges, dust, dirt or other materials such as oil, grease or concrete formwork release agents before installation commences.

13.2 The relative humidity of the concrete must be 75% or less before membrane application. Concrete substrates can be checked for dryness by using a hygrometer as set out in BRANZ Bulletin No. 424. The plywood and timber substructure shall have a maximum moisture content of 20%.

13.3 All voids, cracks, holes, joints and excessively rough areas must be filled to achieve an even and uniform surface. Junctions of substrate abutments, such as at wall/floor and wall/wall junctions greater than 3 mm must be detailed and installed as set out in the Technical Literature.

Membrane Installation

14.1 Installation must not be undertaken where the substrate surface temperature is below 5°C or above 35°C.

14.2 The membrane must be applied as per the Technical Literature.

14.3 Adhesive application can be made by brush, roller or sprayer.

14.4 Clean up of the adhesive may be undertaken with water.

Tiling

15.1 The installed membrane must be protected at all times to prevent mechanical damage, so may require temporary covers until the finishing is completed.

15.2 Tiling must be undertaken in accordance with AS 3958.1 and BRANZ "Good Practice Guide Tiling". The compatibility of the tile adhesive must be confirmed with Ardex New Zealand Limited.

Inspections

16.1 Critical areas of inspection are:

- Construction of substrates, including crack control and installation of bond breakers and movement control joints.
- Moisture content of the substrate prior to the application of the membrane.
- Acceptance of the substrate by the membrane installer prior to application of the membrane.
- Installation of the membrane to the manufacturer's instructions.

Health and Safety

17.1 Safe use and handling procedures for the membranes are provided in the Technical Literature. The materials must be used in conjunction with the relevant Material Safety Data Sheet.

Basis of Appraisal

The following is a summary of the technical investigations carried out:

Tests

18.1 The following testing of Ardex Undertile Sheet Membrane (WPM 750) has been undertaken by various organisations:

- Testing to AS/NZS 4858: 2004.
- Testing for cyclic movement, adhesion to substrates, resistance to aging, resistance to water, resistance to chemicals and water absorption.

The above test methods and results have been reviewed by BRANZ and found to be satisfactory.

Other Investigations

19.1 An assessment was made of the durability of the Ardex Undertile Sheet Membrane (WPM 750) by BRANZ technical experts.

19.2 Site visits have been carried out by BRANZ to assess the practicability of installation and to examine completed installations.

19.3 The Technical Literature has been examined by BRANZ and found to be satisfactory.

Quality

20.1 The manufacture of the membrane has been examined by BRANZ and details regarding the quality and composition of the materials were obtained by BRANZ and found to be satisfactory.

20.2 The quality management system of the membrane's manufacturer has been assessed and found to be satisfactory.

20.3 The quality of manufacture of the membrane is the responsibility of the manufacturer.

20.4 The quality of supply of the membrane system materials to the market is the responsibility of Ardex New Zealand Limited.

20.5 Quality on site is the responsibility of the Ardex New Zealand limited approved and trained applicators.

20.6 Designers are responsible for the substrate design, and building contractors are responsible for the quality of construction of substrate systems in accordance with the instructions of the substrate manufacturer, Ardex New Zealand Limited and this Appraisal.

20.7 Building owners are responsible for the maintenance of the tiling or stone finishing systems in accordance with the instructions of Ardex New Zealand Limited Ltd.

Sources of Information

- AS 2908.2: 2000 Cellulose-cement products - flat sheet.
- AS 3740: 2010 Waterproofing of wet areas within residential buildings.
- AS 3958.1: 1991 Guide to the installation of ceramic tiles.
- AS/NZS 1170: 2002 Structural design actions.
- AS/NZS 4858: 2004 Wet area membranes.
- AS/NZS 2269: 2008 Plywood - Structural.
- NZS 3101: 1995 The design of concrete structures.
- NZS 3604: 2011 Timber-framed buildings.
- NZS 4229: 1999 Concrete masonry buildings not requiring specific engineering design.
- NZS 4230: 1990 Code of practice for the design of masonry structures.
- New Zealand Building Code Handbook Department of Building and Housing, Third Edition September 2010.
- The Building Regulations 1992.
- Good Practice Guide Tiling, BRANZ, March 2004.
- Good Practice Guide Membrane Roofing, BRANZ , October 2003.



BRANZ

In the opinion of BRANZ, [Ardex WPM 750 Undertile Butynol Wet Area Membrane](#) is fit for purpose and will comply with the Building Code to the extent specified in this Appraisal provided it is used, designed, installed and maintained as set out in this Appraisal.

The Appraisal is issued only to [Ardex New Zealand Limited](#), and is valid until further notice, subject to the Conditions of Appraisal.

Conditions of Appraisal

1. This Appraisal:
 - a) relates only to the product as described herein;
 - b) must be read, considered and used in full together with the technical literature;
 - c) does not address any Legislation, Regulations, Codes or Standards, not specifically named herein;
 - d) is copyright of BRANZ.
2. [Ardex New Zealand Limited](#):
 - a) continues to have the product reviewed by BRANZ;
 - b) shall notify BRANZ of any changes in product specification or quality assurance measures prior to the product being marketed;
 - c) abides by the BRANZ Appraisals Services Terms and Conditions.
 - d) Warrants that the product and the manufacturing process for the product are maintained at or above the standards, levels and quality assessed and found satisfactory by BRANZ pursuant to BRANZ's Appraisal of the product.
3. BRANZ makes no representation or warranty as to:
 - a) the nature of individual examples of, batches of, or individual installations of the product, including methods and workmanship;
 - b) the presence or absence of any patent or similar rights subsisting in the product or any other product;
 - c) any guarantee or warranty offered by [Ardex New Zealand Limited](#).
4. Any reference in this Appraisal to any other publication shall be read as a reference to the version of the publication specified in this Appraisal.
5. BRANZ provides no certification, guarantee, indemnity or warranty, to [Ardex New Zealand Limited](#) or any third party.

For BRANZ

P Burghout
Chief Executive

Date of issue: 12 August 2011



ARDEX WPM 750

Undertile Butynol®

Rubber Membrane Waterproofing System

DISCLAIMER The technical details, recommendations and other information contained in this data sheet are given in good faith and represent the best of our knowledge and experience at the time of printing. It is your responsibility to ensure that our products are used and handled correctly and in accordance with any applicable New Zealand Standard, our instructions and recommendations and only for the uses they are intended. We also reserve the right to update information without prior notice to you to reflect our ongoing research and development program. Country specific recommendations, depending on local standards, codes of practice, building regulations or industry guidelines, may effect specific installation recommendations. The supply of our products and services is also subject to certain terms, warranties and exclusions, which may have already been disclosed to you in prior dealings or are otherwise available to you on request. You should make yourself familiar with them.

ARDEX WPM 750

Undertile Butynol® - Rubber Membrane Waterproofing System

UNDERTILE BUTYNOL® SPECIFICATION

Ardex WPM 750 (Undertile Butynol®) is made up of synthetic rubber with properties which resist ageing from heat, sunlight and ozone and is heat weldable. Polypropylene filaments are welded onto both sides of the membrane for better wetting by water based adhesives. It has excellent gas impermeability and toughness and remains flexible at low temperatures.

Laps and corners are to be heat formed and/or welded. Tiling can be done directly on the membrane after 60 minutes with common Ardex tiling adhesives like X77, X56 STS8/E90, Quickbond/Abalastic, 2 part Optima or ABAFLEX.

Undertile Butynol® is marketed by Ardex as a warranted undertile waterproofing product using solvent free adhesives and fixed by their trained and experienced approved Applicators.

UNDERTILE BUTYNOL® MATERIAL SPECIFICATIONS

Our requirements for long term warranty necessitate that the Undertile Butynol® meets these typical technical requirements:

Specific Gravity to ASTM D297	1.30±0.05
Hardness IRHD to ASTM D1415	65±5
Tensile Strength to ASTM D412	4.86 MPa min
Elongation at break to ASTM D412	300% min
Water Absorption to ASTM D471	1.65% (by mass)
(for 1mm Butynol®)	0.72% (by volume)
Water Permeability to ASTM E96-92	
Vapour Flow Resistance (for 1mm Butynol®)	12414 (MNs/g)
Vapour Flow Rate (for 1mm Butynol®)	0.013 (g/m ² d)

Note: Interesting comparable figures for water permeability are –

Polythene 156, Asphalt 1830, P.V.C. 4900

K Values on 1mm Butynol® sheeting

K Value (Thermal Conductivity): 7.4 x 10³Cal/cm/sec/deg C

UNDERTILE BUTYNOL® GAUGES

Standard 0.5mm – For undertile waterproofing

RESISTANCE

Undertile Butynol® resists tearing, flex cracking, bubbling and abrasion. It is extremely strong, has a long life and is versatile.

PACKAGING

Rolls of nominal 1.4m x 20m long. Rolls are packed in polythene wrapper trademarked Undertile Butynol®.

SUBSTRATE SPECIFICATION

Plywood & TimberSubstrates must be dry when Undertile Butynol® is applied. The plywood and timber substructure shall have a maximum moisture content of 20% when Undertile Butynol® is adhered.

NOTE: The use of LOSP (Light Organic Solvent Preservative) treated plywood must NOT be used under Undertile Butynol® in any circumstances or conditions.

OTHER SUBSTRATE TYPES

Fibre cement compressed sheet, closed cell polyurethane foam, wet wall linings i.e. Gib Aqualine, VillaBoard.

New Concrete

Must be cured for a minimum of 28 days and all curing compounds removed prior to application. A reduction in cure time can be achieved by utilising the Ardex HydrEpoxy System (consult Ardex Technical Department for details)

Old Concrete

Must be clean from any contaminants prior to application

ADHESIVES FOR USE WITH UNDERTILE BUTYNOL®

WPM 09A The standard contact brushing, spray grade and rolling solvent free adhesive for fixing to the substrate. Supplied in 20L plastic containers.

WPM 09C Catalyst to assist adhesion in adverse conditions.

DURABILITY

Undertile Butynol® when fixed according to Ardex instruction will meet the NZBC requirements of B2.3.1(b) 15 years.

Refer BRANZ Appraisal Certificate No 727 2011.

PRODUCT WARRANTY

When laid by an approved Applicator in accordance with Ardex's specifications, a material warranty for up to 20 years is available. Ardex is not responsible for any costs arising from installation of the Membrane and does not provide any warranty other than where a written Ardex material warranty has been issued.

WORKMANSHIP

A warranty for workmanship shall be provided directly by the approved Applicator. The period and terms of the workmanship warranty shall be determined by the conditions of the contract or the approved Applicator.

TYPICAL ARCHITECTURAL UNDERTILE BUTYNOL® SPECIFICATION

1. Preliminary

Refer to the Preliminary & General Clauses of this specification and to the General Conditions of Contract which are equally binding on all trades. This section of the specification shall be read in conjunction with all other sections.

2. Scope

This section of the contract consists in general of the provision and laying of the Undertile Butynol® in wet areas.

3. Workmanship

The whole of the work shall be carried out by skilled tradesmen using adequate and proper equipment and methods in accordance with best trade practice, and following the specifications, methods and recommendations as laid down by the manufacturers.

4. Sub-contractors

The work included in this section of the contract shall be carried out by a firm of waterproofing experts conversant with and specialising in the supply and fixing of this materials and shall be a firm approved by Ardex.

5. Warranty

When laid by an approved Applicator in accordance with Ardex's specifications, a written material warranty of up to 20 years is available. It is the responsibility of the approved Applicator to confirm proper installation and to request Ardex to issue a material warranty on behalf of the customers following completion of installation. Ardex is not responsible for any costs arising from installation and does not provide any warranty other than where a written Ardex material warranty has been issued.

6. Materials

6.1 Undertile Butynol® Membrane

Shall be 0.5mm thick Undertile Butynol® in all wet area surfaces, where membrane is to be overlaid with tiles.

6.2 Adhesives

Shall be recommended by Ardex specially formulated for Undertile Butynol® and suitable for the particular application and the relevant temperature and conditions applicable.

7. Laying of Undertile Butynol®

The Undertile Butynol® installer shall check the substrate before laying any membrane to ensure that the surface is completely sound, screw fixed to specifications: screw heads flush, sheets spaced to provide for thermal movement or shock.

8. Completion

On completion carefully and thoroughly clean off and remove all scraps and other rubbish from finished surfaces and leave in tidy order.

9. Extent of Work

Observe the foregoing specification and supply and lay Undertile Butynol® sheeting to all wet areas as shown and detailed in the drawing and in accordance with AS/NZS3740. Failure to comply with the above specifications will result in all warranties being null and void.

LAYING SPECIFICATION

The sub-contractor for the work called for in this trade will be a Company or Person approved by Ardex. The approved installer shall examine all drawings and provide for the surface to which Undertile Butynol® is to be fixed shall be clean, smooth, dry and free from sawdust, grit or sharp objects. Membrane laying shall not start until defects have been corrected. On completion the installer will provide the owner with a Workmanship Warranty and obtain from Ardex a Materials Warranty. Failure to comply with the above specifications will result in all warranties being null and void.

INSTALLATION

Roll out Undertile Butynol® and cut to the measured length. Smooth Undertile Butynol® on contact to minimise air entrapment beneath the membrane. Floor sheets of Undertile Butynol® must extend up the wall at least 150mm. Make sure the Undertile Butynol® is laid tightly into all corners. Wall sheets of Undertile Butynol® should overlap the 150mm upstand. Weld seams and laps with the Leister Triac S Hot Air Gun. Roll with a rubber roller to ensure seams and laps are secure.

Walls, internal corners & transitions

Apply the Undertile Butynol® membrane 1800mm up the walls or to a height of 150mm above the shower rose. For unenclosed showers the membrane must extend a minimum of 1500mm out from the shower rose.

PROTECTION

Undertile Butynol® is not suitable as a trafficable surface.

Undertile Butynol® is compatible with undertile heating systems. For electric undertile heating, the wire must be laid under the membrane.

It is the responsibility of the main building contractor to ensure all sub-trades likely to be working in the vicinity of the membrane are aware that a waterproofing membrane has been installed and all care must be taken to protect the membrane from damage. The tiler must lay tiles in accordance with best practice guidelines.

ARDEX WPM 750

Undertile Butynol® - Rubber Membrane Waterproofing System

LAYING UNDERTILE BUTYNOL® IN BATHROOM WET AREAS in accordance with AS/NZS 3740

Extent of treatment of wet areas - shower area over bath - unenclosed shower

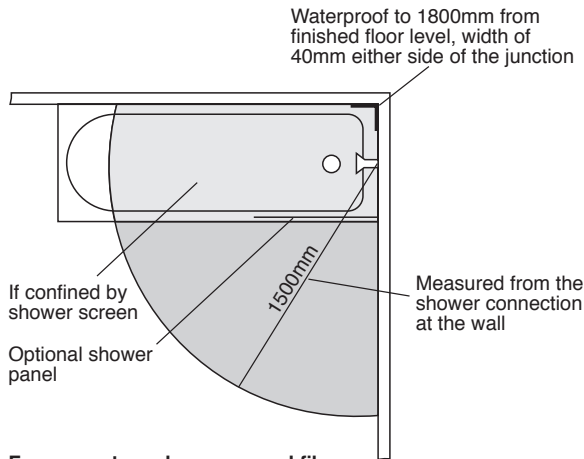

For concrete and compressed fibre cement sheet floors

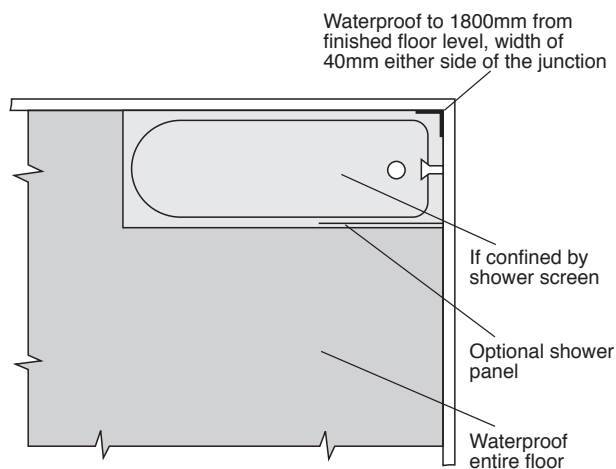

For timber floors including particleboard, plywood and other flooring materials apply Undertile Butynol® waterproofing membrane to entire floor

Enclosed shower

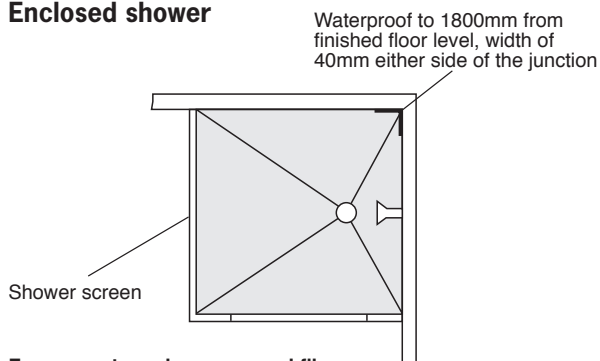

For concrete and compressed fibre cement sheet floors

TYPICAL SHOWER CONSTRUCTION

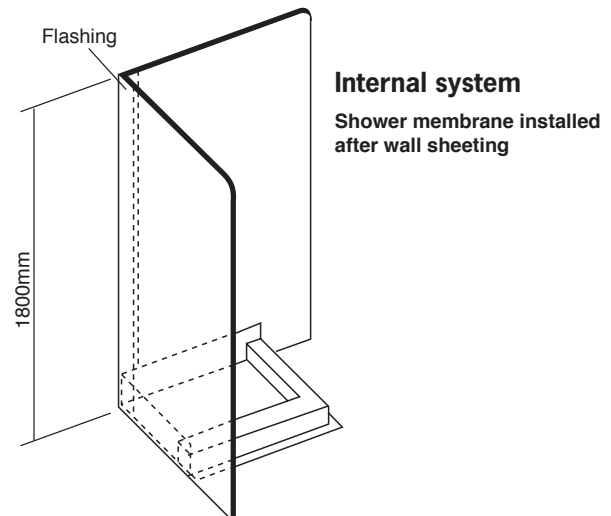
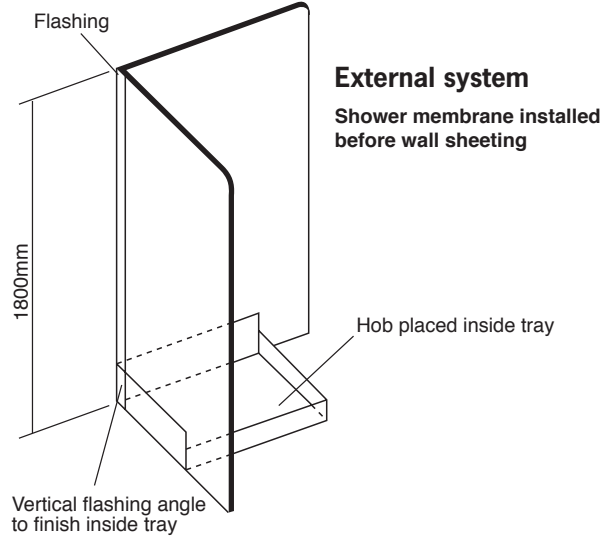

TYPICAL HOB CONSTRUCTION

The shower screen to be installed so as to be flush with the shower area side of the hob or overhanging into shower area

For showers with hobs and stepdowns Undertile Butynol® to be applied to minimum height of 150mm above finished level of the floor or 25mm above maximum retained water level (whichever is the greater)

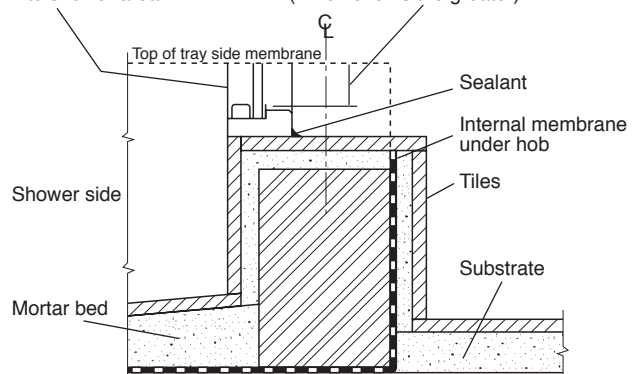



ARDEX Butynol® Shingles

DISCLAIMER The technical details, recommendations and other information contained in this data sheet are given in good faith and represent the best of our knowledge and experience at the time of printing. It is your responsibility to ensure that our products are used and handled correctly and in accordance with any applicable New Zealand Standard, our instructions and recommendations and only for the uses they are intended. We also reserve the right to update information without prior notice to you to reflect our ongoing research and development program. Country specific recommendations, depending on local standards, codes of practice, building regulations or industry guidelines, may effect specific installation recommendations. The supply of our products and services is also subject to certain terms, warranties and exclusions, which may have already been disclosed to you in prior dealings or are otherwise available to you on request. You should make yourself familiar with them.

ARDEX Butynol® Shingles

LAYING ARDEX BUTYNOL® DIAMOND SHINGLES

Setting Out

1. Mark the substrate horizontally with a chalk line 350mm up from bottom.
2. Mark a vertical line, top to bottom, and centre of the roof.
3. Mark off 300mm vertical spacings from the centre vertical line (both sides).

Laying

1. Cut a starter flashing wide enough to cover the first 350mm at the bottom edge of the roof, up to the horizontal chalk line, allowing extra in width for gutter or fascia flashing.
2. Apply adhesive, and lay when ready.
3. Starting from the centre vertical chalk line, loose lay the first shingles, making sure that the top and bottom are in line with the vertical marking. Now loose lay the entire bottom row, making sure each shingle is butted up to each other.
4. With chalk, mark the starter flashing where the adhesive should be applied using the loose laid shingles to mark around. This is to eliminate over brushing of adhesive.
5. Remove loose laid shingles and apply adhesive to substrate and shingles which are to be laid (up to 5 shingles are manageable at one time).
6. Lay when ready, starting with centre shingle and making sure each shingle aligns with vertical markings and is well butted together.
7. Lay entire bottom row first.
8. Following rows are laid identically, but are staggered and overlap row below by 25mm.
9. Each shingle must be carefully rolled, paying special attention to lapped edges.
10. The top row of shingles may be cut to suit the specifications and a Butynol® overflashing used to finish the ridge.

Any excess adhesive should be cleaned off as you go with WA98 solvent.

Roof area coverage of 50 shingles is approximately 8.82m².

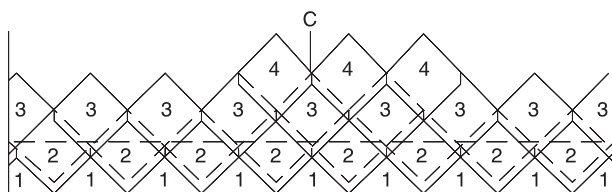

After doing 350mm bottom flashing #1, then start laying full shingles #2, #3, #4 etc.

Always start from centre on first row.

LAYING ARDEX BUTYNOL® STANDARD SHINGLES

Priming Substrate

In areas where rain could interrupt work, it is recommended that a primer coat of WA98 adhesive be applied to substrate to prevent penetration of moisture.

Underflashings

Glue and fix Butynol® 380mm underflashing down barges, valleys, hips etc. and also along the bottom of the roof allowing an overhang into the gutter.

Laying

1. Make a chalk line horizontally along the roof, one shingle height up. This line marks the top of the first row of shingles. Apply adhesive by brush or roller to substrate and shingle - approximately five at a time for one person - pulling off plastic backing before doing so. After flashing off time locate the top of the shingle on the chalk line and smooth down.
2. To locate the next row, mark a horizontal chalk line up one shingle height minus the overlap onto the lower shingle.
3. Each shingle must now be carefully rolled, paying special attention to lapped edges.
4. The top row of shingles may be cut to suit the apex and a Butynol® overflashing used to finish at the ridge.

Any excess adhesive should be cleaned off as you go, with WA98 solvent.

Roof area coverage of 50 shingles is approximately 3.57m².

Note: Ardex Shingles have a forty-five degree cut on outside edges.

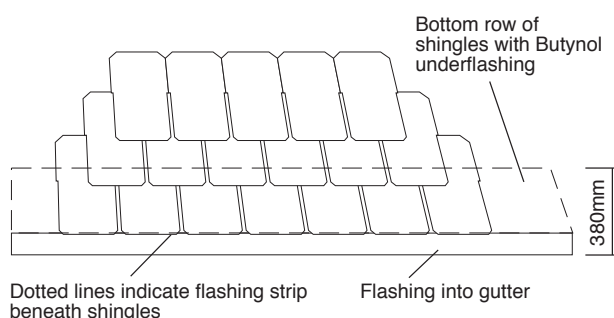

Standard Shingles

Approximately 580x290mm, 50% overlap of the shingle below.

Raumati Shingle

Approximately 540x270mm. A 280x75mm fillet is required to complete the seal.



ARDEX Optima

DISCLAIMER The technical details, recommendations and other information contained in this data sheet are given in good faith and represent the best of our knowledge and experience at the time of printing. It is your responsibility to ensure that our products are used and handled correctly and in accordance with any applicable New Zealand Standard, our instructions and recommendations and only for the uses they are intended. We also reserve the right to update information without prior notice to you to reflect our ongoing research and development program. Country specific recommendations, depending on local standards, codes of practice, building regulations or industry guidelines, may effect specific installation recommendations. The supply of our products and services is also subject to certain terms, warranties and exclusions, which may have already been disclosed to you in prior dealings or are otherwise available to you on request. You should make yourself familiar with them.

ARDEX Optima

DESCRIPTION

Ardex Optima is a two component cementitious acrylic modified white adhesive. When mixed in the recommended portions Ardex Optima produces a resilient water resistant adhesive for bonding most ceramic tiles to Butynol® Synthetic Rubber and other substrates (see below).

APPLICATION RANGE

Location

Internal, external and water immersion.

Performance Levels

Residential, commercial and industrial.

Surfaces

Walls, floors and decks.

Tiles

Natural stone, porcelain, mosaics, fully vitrified & ceramic tiles.

Uses

Particularly suited for adhering ceramic and clay tiles to Butynol® decking and facings as per the Ardex recommended direct-stick system described below.

Other suitable substrates

- Brick and blockwork
- Fibre cement sheets, plaster boards
- Tilt up and pre-cast concrete
- Cement render, concrete, aerated concrete
- Powder coated cladding, galvanised, stainless steel (degreased), brass
- Existing tiles (thoroughly cleaned)
- Superflex and Shelter acrylic waterproofing membranes
- Particleboard
- Roughened fibreglass

SUBSTRATE PREPARATION

Butynol

Butynol® must be cleaned to remove any dust or contaminants. This can usually be accomplished by using sugar soap and water, but if more stubborn soils remain, contact your local Ardex representative for instruction. Allow surface to dry before applying adhesive.

MIXING

Mixing ratio three parts of powder by weight to one part of liquid (weight or volume).

Mix adhesive by mechanical means until a homogeneous creamy paste is achieved, do not over mix. Allow mix to stand for 2 minutes prior to use.

APPLICATION

Tile installation must conform to the requirements of the Australian Standard 4992-2003.

Lay the tiles using Ardex Optima applied to the membrane surface using a 12mm notched trowel to achieve a dry bed thickness of not less than 2.5 - 3mm. Place the tiles in position and work into the adhesive to ensure a 100% coverage to the reverse side of the tiles. Only spread the adhesive to an area of approximately 1m² at a time to ensure that the tiles can be placed before the adhesive forms a surface skin which will inhibit the bond strength.

Allow the Ardex Optima to cure for at least 24 hours before proceeding with the next stage. Low absorbency tile can extend the cure time.

Tiles may also be adhered to a removeable layer of Ardex DS60 to comply with (E2 7.3.1.1) with the ability to lift the top surface off when necessary.

GROUTING OF TILES

All joints should be grouted using Ardex Grouts with Grout Booster (80:20) after the adhesive has fully cured. After mixing the grout in accordance with the instructions work it well into the joints ensuring there are no voids under the grout. Apply the grout to a small area of approximately 1m² at a time and clean excess grout from that area prior to proceeding. Only mix small quantities of grout at a time to enable workability within the pot life of the product.

Finishing Ardex Grouts should be carried out in the normal fashion by allowing the residual grout film to dry and polish off to totally remove.

Abapoxy

When using Ardex Abapoxy, cleaning the excess grout from the surface should be carried out using a wet cloth wrapped around a firm rectangular item such as a block of wood to remove the bulk of the excess. Surface should be finally cleaned using a clean wet scourer to remove all excess material from the joints and the tile surfaces.

COVERAGE

One 30kg/10L unit will cover 6m² using a 12mm notched trowel at the specified dry bed thickness of 2.5 - 3mm.

PACKAGING

Mini Kit (1.7L liquid/5kg powder)

Large Kit (10L liquid/6x5kg powder)

DRYING

Approximately 24 hrs at 23°C, 50% RH, allow longer for colder conditions.

STORAGE AND SHELF LIFE

12 months when stored at 5°C - 25°C in airtight, sealed container.

CAUTION

High temperatures caused by heat absorption by black Butynol® will accelerate drying time.

TECHNICAL DATA

Type	Two Part
Colour	White
Specific Gravity of liquid	1.02
pH	7.5
Application Properties (@ 23°C, 50% RH)	
Mixing Ratio	Powder/Liquid 30kg/10kg
Specific Gravity of Mix	1.67kg/litre
Viscosity of Mix	148,000 cps
Open Time	25 minutes
Adjustability Time	20 minutes
Pot Life	45 minutes
Water Absorption	1.18%
Mechanical Properties	
Shear Bond Strength (MPa)	
7 days dry	2.7
14 days dry	3.56
7 days water immersion	2.86
8 month immersion in fresh water concrete pool	3.1
Tensile Strength (MPa)	
7 days	2.3





ARDEX Bonding/ Seam Primer

Solvent Based Primer

DISCLAIMER The technical details, recommendations and other information contained in this data sheet are given in good faith and represent the best of our knowledge and experience at the time of printing. It is your responsibility to ensure that our products are used and handled correctly and in accordance with any applicable New Zealand Standard, our instructions and recommendations and only for the uses they are intended. We also reserve the right to update information without prior notice to you to reflect our ongoing research and development program. Country specific recommendations, depending on local standards, codes of practice, building regulations or industry guidelines, may effect specific installation recommendations. The supply of our products and services is also subject to certain terms, warranties and exclusions, which may have already been disclosed to you in prior dealings or are otherwise available to you on request. You should make yourself familiar with them.

ARDEX Bonding/Seam Primer

Solvent Based Primer

DESCRIPTION

Bonding Primer solvent based primer is designed to lock particles on the substrate to achieve maximum adhesion. It has excellent durability and is a low viscosity binder that seals absorbent substrates and penetrates dust.

TYPICAL APPLICATIONS

- New and old concrete
- Timber
- Compressed fibreboards
- Primer for acrylic coatings

APPLICATION REQUIREMENTS

General

Do not apply Bonding Primer if the temperature is below 5°C or above 35°C.

Substrate preparation

The surface to be coated should be dry, clean, sound and free from oil, grease and flaking paint. New concrete should be left a minimum of 28 days before application commences. All cracks or holes exceeding 2mm are to be repaired before application commences.

APPLICATION SPECIFICATION

Apply with brush, long nap roller or conventional spray. Ensure that the coating is applied evenly at the recommended coverage rates. Allow a drying time of at least one hour.

COVERAGE

Approximately 5-8m²/litre on horizontal and vertical surfaces.

PACKAGING

4 litre and 1 litre cans.

CLEAN UP

Clean all equipment in general purpose thinners immediately after use.

STORAGE

Bonding Primer must be stored above 6°C.

SHELF LIFE

One year in unopened containers stored at 20°C.

SAFETY DIRECTIONS

Avoid contact with skin and inhalation of the vapour. Provide adequate ventilation. Keep out of reach of children. If swallowed contact a doctor or Poisons Information Centre.

Contact Ardex for specific applications and material safety data sheet.



ARDEX CA 20 P

Multipurpose Construction Adhesive and Sealant (Butynol® Sealant)

- Can be used underwater, ideal for minor repair applications
- Extremely versatile - bonds a wide range of materials including metal, glass, wood, ceramics and plastic
- Use to seal expansion and connection joints
- Extremely flexible
- High initial tack and bond strength
- Neutral curing system - free of solvents, water and isocyanates
- Can be over painted
- Shrinkage free drying
- Single component Silane Modified Polymer (SMP)
- Internal and external, wall and floor
- Low VOC content - meets Green Building Council of Australia Green Star IEQ-13 requirements

DISCLAIMER The technical details, recommendations and other information contained in this data sheet are given in good faith and represent the best of our knowledge and experience at the time of printing. It is your responsibility to ensure that our products are used and handled correctly and in accordance with any applicable New Zealand Standard, our instructions and recommendations and only for the uses they are intended. We also reserve the right to update information without prior notice to you to reflect our ongoing research and development program. Country specific recommendations, depending on local standards, codes of practice, building regulations or industry guidelines, may effect specific installation recommendations. The supply of our products and services is also subject to certain terms, warranties and exclusions, which may have already been disclosed to you in prior dealings or are otherwise available to you on request. You should make yourself familiar with them.

ARDEX CA 20 P

Multipurpose Construction Adhesive and Sealant (Butynol® Sealant)

DESCRIPTION

Ardex CA 20 P has been specially designed and formulated for sealing Butynol® flashings into chases. Ardex CA 20 P has excellent sealing and adhesive properties to Butynol® and a variety of building components.

Ardex CA 20 P is a one component, silane modified polymer adhesive and neutral curing sealant which hardens in reaction with moisture. Ardex CA 20 P is extremely flexible, with a high initial tack and good bond strength, making it suitable for a wide range of applications. It is ideal as a general shower, kitchen and bathroom repair adhesive and sealant for replacing tiles, fitting accessories such as soap holders and finishing off joints. Its shrinkage free drying and ability to be used internally and externally on walls and floors adds to the versatility of Ardex CA 20 P.

It can be used in underwater applications, either applied to the immersed substrate or to the item to be fixed, making it ideal when minor repairs and alterations need to be carried out.

USE

Ardex CA 20 P is ideal for bonding most construction materials including glass, tiles, ceramics, wood, plastic and metal. It can also be used for repairing areas of loose tiles, carpet or vinyl, for fixing decorative, acoustic and thermal insulation panels as well as decorative beams and sections, also for fixing skirting boards, cable ducts, mirrors, bathroom and shower accessories, and door handles.

Ardex CA 20 P can be used for elastic joints between wood, plastic, metal and ceramic materials or for sealing expansion and connection joints.

Ardex recommend a trial application to optimise the conditions for particular applications.

TO (Substrates)

Include concrete, wall panels, timber, waterproofing membranes, glazed and unglazed ceramic tiles, aluminium, plastics, metal, glass, fibreglass and polystyrene foam.

SUBSTRATE PREPARATION

In general, the substrate or joint must be clean, firm and free of dust, dirt, oil, grease, curing compounds, old adhesive residues, paints, coatings, bitumen, tar, release agents and other barrier materials.

APPLICATION

Remove aluminium seal at the bottom of the cartridge, pierce the protective membrane at the tapered nozzle, attach and trim nozzle to required size and place cartridge in applicator gun.

When using Ardex CA 20 P at low temperatures, it is advisable to pre-warm the cartridge in warm water.

Do not apply Ardex CA 20 P at temperatures below 5°C or above 35°C.

Apply Ardex CA 20 P in stripes to the substrate or to the item to be fixed. Press the items firmly together within 7-10 minutes after application (at a temperature of 20°C) and before skinning of the adhesive starts. If using the product for spot fixing repairs, ensure that the maximum distance between glue points is 25 to 30cm and observe the weight of the item being fixed.

The drying time depends on the substrate, climatic conditions and the materials being fixed. Higher humidity will shorten the open time, while lower humidity will extend the open time.

Close open cartridges and reuse as soon as possible. Note: Always remove a small layer of any skinned adhesive before reusing.

If in doubt about characteristics, carry out a trial application. Spillage can be removed when wet using a clean cloth. If the material has dried then scraping with a blade will be required.

PACKAGING

Ardex CA 20 P is packed in a metal cartridge - 310ml net volume.

SHELF LIFE

Ardex CA 20 P has a shelf life of not less than 12 months when stored in the original, unopened packaging, in a dry place at 23°C and 50% relative humidity.

Pay attention to the following:

Ardex CA 20 P achieves a good bond underwater. We recommend a trial application to ensure a good bond is achieved. The long-term stability when fixed underwater may vary depending on application.

Ardex CA 20 P can be over painted after drying with most commonly used paints; due to the vast range of paints and coatings on the market we recommend a small test area prior to proceeding.

Do not use Ardex CA 20 P for chemical resistant applications, use Ardex epoxy grouts.

Fixing onto fibreglass, with or without grinding the glaze, is recommended only for small repair applications, especially in swimming pools.

SAFETY PRECAUTIONS

Use in well ventilated areas. Avoid skin and eye contact. If uncured material makes contact with the eye, flush with clean water for 15 minutes and seek medical advice.

In case of skin contact, first wipe the skin with a dry cloth then wash with soap and water. If respiratory discomfort is experienced, move to an area for fresh air. If swallowed, drink plenty of water in small portions, do not induce vomiting and seek medical advice. Keep out of reach of children.

Contact Ardex for specific applications and material safety data sheet.

TECHNICAL DATA

Material Base	Silane Modified Polymer
Colour	White paste
Specific Gravity	approx 1.45kg/litre
Application Properties (@ 23°C, 50% RH)	
Application Temperature	5°C to 35°C
Skimming/Open Time	approx 7-10 minutes
Curing Time	3-4mm/24 hours
Shrinkage	<1%
Temperature Resistance	-40°C to +90°C (short term of 15-20 minutes up to +200°C)
Practical Expansion	25%
Material Requirement	30-40ml/m
Hardness, Shore A	approx 40
Mechanical Properties	AS 4992
Shear Adhesion Strength	>2MPa
Tensile Adhesion Strength	1.0N/mm ²

FLASHING INTO CONCRETE WALLS

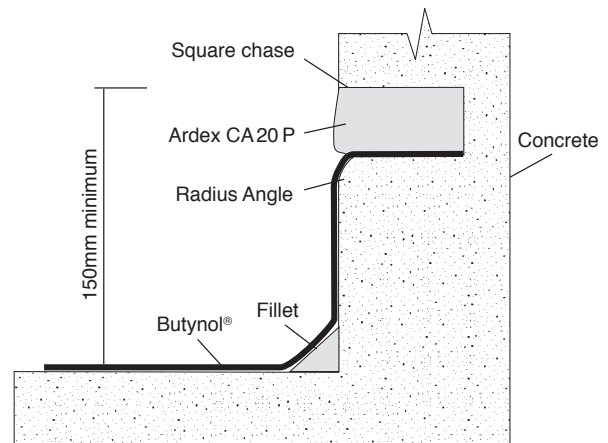

Butynol® is glued into square chase and finished with Ardex CA 20 P.

